

Journal für

Reproduktionsmedizin und Endokrinologie

– Journal of Reproductive Medicine and Endocrinology –

Andrologie • Embryologie & Biologie • Endokrinologie • Ethik & Recht • Genetik
Gynäkologie • Kontrazeption • Psychosomatik • Reproduktionsmedizin • Urologie



Pharmacology of Progestogens

Kuhl H

J. Reproduktionsmed. Endokrinol 2011; 8 (Sonderheft
1), 157-177

www.kup.at/repromedizin

Online-Datenbank mit Autoren- und Stichwortsuche

Offizielles Organ: AGRBM, BRZ, DVR, DGA, DGGEF, DGRM, D-I-R, EFA, OEGRM, SRBM/DGE

Indexed in EMBASE/Excerpta Medica/Scopus

Krause & Pachernegg GmbH, Verlag für Medizin und Wirtschaft, A-3003 Gablitz



ENDO FERTI FORUM

ENDOKRINOLOGIE & FERTILITÄT
FÜR KLINIK & PRAXIS

20.-21. März 2026

Universitätsmedizin Mainz

Einladung zu unserer wissenschaftlichen Veranstaltung Endo-Ferti-Forum

Brücke(n) zwischen Unikliniken und Praxen an Rhein und Main(z)

– die aus dem bisherigen Format „Ferti Forum“ ab 2026 hervorgeht –



Freuen Sie sich auf spannende Vorträge und den lebendigen Austausch mit Kolleg:innen und Expert:innen aus Klinik und Praxis. Freitagabend laden wir Sie herzlich zu einem entspannten Empfang ein – eine perfekte Gelegenheit, Kontakte zu knüpfen und den Tag genussvoll ausklingen zu lassen.

Wissenschaftliche Leitung: Univ.-Professorin Annette Hasenburg, Dr. Susanne Theis, Universitätsmedizin Mainz, Sanitätsrat Dr. Werner Harlfinger, BVF Rheinland-Pfalz Dr. Rüdiger Gaase, BVF Hessen Dr. Klaus J. Doubek

Schirmherrschaften: Prof. Nicole Sängler, Uniklinik Bonn, Prof. Jan-Steffen Krüssel, Uniklinik Düsseldorf, Dr. Annette Bachmann, Uniklinik Frankfurt am Main, Prof. Christine Skala, Uniklinik Köln

Weitere Informationen
& Anmeldung unter



Pharmacology of Progestogens*

H. Kuhl

This review comprises the pharmacokinetics and pharmacodynamics of natural and synthetic progestogens used in contraception and therapy. The paper describes the historic development of progestogens, their mechanisms of action, the relation between structure and hormonal activity, differences in hormonal pattern and potency, peculiarities in the properties of certain compounds, tissue-specific effects, and metabolism. The influence of the route of administration on pharmacokinetics, hormonal activity and metabolism is discussed. The various types of progestogens including tibolone, their receptor interaction, hormonal pattern and the hormonal activity of certain metabolites are described in detail. The structural formula, serum concentrations, binding affinities to steroid receptors and serum binding globulins, and the relative potencies of the available progestins are presented. The different pathways of aromatization of natural androgens as compared to that of norethisterone and tibolone are discussed. Differences in the tissue-specific effects of the various compounds and regimens and their potential implications with the risks and benefits of treatment are described. **J Reproduktionsmed Endokrinol 2011; 8 (Special Issue 1): 157–76.**

Key words: progestogens, pharmacokinetics, pharmacodynamics

■ Introduction

The close association between pharmacokinetics and pharmacodynamics indicates the importance of pharmacological knowledge for an appropriate use of sex steroids for contraception or therapy. However, even though there is a significant correlation between the serum concentrations of sex hormones and, e.g., the frequency of postmenopausal hot flashes, the serum level of an individual woman does not reflect the clinical effects [2]. Similarly, extensive measurement of pharmacokinetics of contraceptive steroids during the use of estrogen/progestin combinations did not reveal any association with the occurrence of irregular bleeding or other complaints [3].

This casts considerable doubts on the usefulness of regular measurements of hormone levels for the prediction or control of therapeutic or adverse effects. Another claim which turned out to be incorrect, was the story of an advantage of constant hormone levels observed during parenteral treatment as compared to the rapid rise and fall after oral administration. The striking effectiveness and tolerability of intranasal estradiol therapy which is associated with extremely high peak levels occurring within a few minutes after administration and a rapid fall thereafter, refuted this general opinion [4, 5].

■ The Physiological Role of Progestogens

Originally, progestogens which comprise the natural progesterone and a series of synthetic progestins, were defined as compounds that maintain pregnancy. In the sixties, progestins were generally used to support early pregnancies without any evidence of benefit. Since many years it is known that in the human only progesterone is capable of maintaining pregnancy.

Endogenous progesterone is essential for the function of the cervix, uterus, endometrium, tubes, the central nervous system, pituitary, and the breast. As progesterone is rapidly metabolized in the intestinal tract, liver and other tissues, its effectiveness is dependent on the galenic preparation, and – if administered orally or vaginally – on a high dosage. Therefore, most preparations contain a synthetic progestogen (progestin) which can be used at relatively low doses because its inactivation is slowed down owing to structural peculiarities.

Progestogens are clinically used for special therapeutic indications (e.g., bleeding disorders, benign breast disease, endometriosis), hormone replacement therapy (HRT), and hormonal contraception. In hormone replacement therapy, the only indication for the use of progestogens is the prevention of estro-

gen-induced endometrial hyperplasia, because a long-term unopposed estrogen action increases the risk of hyperplasia and cancer of the endometrium. Contrary to this, hormonal contraception is essentially dependent on the presence of a progestin which not only suppresses follicular activity and ovulation, but also changes cervical mucus and impairs endometrial and tubal function.

■ Historical Development of Progestogens

From the very beginning of the research on hormonal contraception the interest of scientists was focussed on the anti-ovulatory effects of corpus luteum extracts. Consequently, great efforts were made to isolate the active principle of this organ, and in 1934 four independent groups of scientists succeeded in isolating progesterone and detecting its chemical structure. Subsequent studies and clinical experiences clearly showed that the natural progestogen was hormonally active only after administration per injection. Finally the need for orally active progestogens resulted in the synthesis of the first useful progestin norethisterone by Carl Djerassi and his co-workers. Although orally active estrogens, e.g., diethylstilbestrol (DES) and ethinylestradiol (EE), have been available more than a decade earlier, the first clinical studies on hormonal contraception have been carried out using proges-

* Updated version, portions of this article from [1]. Reprinted with permission by Taylor & Francis Ltd.

Received and accepted: May 1, 2011

From the Department of Obstetrics and Gynecology, Goethe-University, Frankfurt, Germany

Correspondence: Herbert Kuhl, PhD, Professor of Experimental Endocrinology, Department of Obstetrics and Gynecology, Goethe-University, D-60590 Frankfurt am Main, Theodor-Stern-Kai 7; e-mail: h.kuhl@em.uni-frankfurt.de

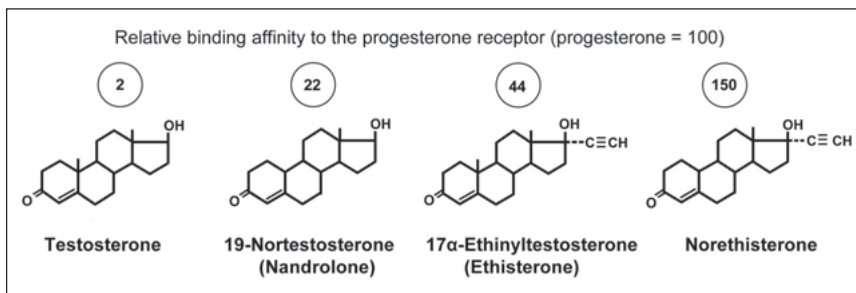

Figure 1. Transition from testosterone to norethisterone and the respective relative binding affinities to the progesterone receptor.

tins. At that time, both DES and EE have been clinically tested at extremely high doses which caused various adverse effects, whereas the first progestins have been demonstrated to be well tolerated.

However, the story of synthetic progestogens is more complicated, as the first orally active compound with progestogenic activity was an androgen. It was in 1938, when the Schering chemists H.H. Inhoffen and W. Hohlweg synthesized an orally highly active estrogen, 17 α -ethinylestradiol, by the addition of acetylene at the C17 α -position of estrone acetate. Subsequently, the yield of the reaction was largely increased using sodium carbide in liquid ammonia [6].

Analogous to this, Hans H. Inhoffen and Walter Hohlweg tried to develop an orally active androgen by means of the same reaction. Still in 1938, they succeeded in synthesizing 17 α -ethinyltestosterone by means of the reaction of the 17-keto group of an androstane derivative with sodium carbide in liquid ammonia. The new hormone was named pregnen-in-one-3-ol-17 and became known as "ethisterone" (Fig. 1) [6, 7]. In contrast to testosterone, it was indeed an orally potent hormone. However, the androgenic activity was not enhanced but attenuated, and surprisingly the compound showed considerable progestogenic activity. This phenomenon is based on structural similarities of the progesterone receptor and the androgen receptor resulting in a certain binding affinity of androgens to the progesterone receptor, and of progestins to the androgen receptor. The latter may cause either an androgen-agonistic or an androgen-antagonistic effect of the progestin. While testosterone has only a weak binding affinity to the progesterone receptor, the removal of the angular methyl group between the A-ring and the B-ring causes a tenfold increase in the binding affinity

to the progesterone receptor (Fig. 1). In 1950, Arthur J. Birch reported on a weaker androgenic potency of 19-nortestosterone as compared to testosterone, and today we know that there is also shift from androgenic to anabolic activity. The introduction of the 17 α -ethinyl group at C17 α into the testosterone molecule leads to ethisterone that shows a more pronounced binding affinity to the progesterone receptor, and both changes, i.e. the 19-nor structure and the ethinylation at C17 α , results in a highly active and well tolerated progestin, norethisterone (Fig. 1).

Animal experiments and clinical studies revealed that 17 α -ethinyltestosterone was indeed an orally potent hormone. However, the androgenic effect was weaker than that of testosterone and, surprisingly, it exerted a considerable progestogenic activity [6]. Therefore, it was marketed in 1939 as the first oral progestin under the name "Proluton C[®]". The recommended indications were the prevention of habitual abortion and treatment of dysmenorrhea at doses between 10 and 60 mg daily [7, 8]. However, before norethisterone was available in 1957, ethisterone was the only orally active progestin and was used for the prevention of abortion at daily doses of up to 250 mg during early pregnancy, and masculinization of female offsprings was observed [9, 10].

In 1944, Maximilian Ehrenstein synthesized a mixture of stereoisomers of 19-norprogesterone that was demonstrated to exert potent progestogenic effects when administered parenterally [11, 12].

Based on these findings M. Ehrenstein concluded that a removal of the angular methyl group between the A-ring and the B-ring leads to an enhancement of the hormonal activity of progestogens [13, 14].

In 1950, the group of Carl Djerassi synthesized a progesterone analog with an aromatic A-ring. Although this compound did neither exert estrogenic nor progestogenic activities, it was an important step on the way to the synthesis of norethisterone, because it lacks the 19-methyl group [13]. At that time, the chemical removal of the 19-methyl group was a very complicated process. It was in 1950, when A. J. Birch published the reduction of the aromatic A-Ring of estradiol resulting in the formation of 19-nortestosterone [15]. Using the Birch reduction, Carl Djerassi and his coworker Luis Miramontes succeeded in 1951 in converting 3-methoxy-estradiol into a 19-nortestosterone derivative that was subsequently transformed by means of several reactions into 17 α -ethinyl-19-nortestosterone (norethisterone) [13]. The progestogenic activity of norethisterone was about 20-fold higher than that of ethisterone.

In the same year, George Rosenkranz und Carl Djerassi also synthesized 19-norprogesterone using the Birch reduction, which was orally inactive, but a potent progestogen after parenteral administration [13]. It is, however, the basic compound of a series of 19-nor progesterone derivatives that have been used in the past (e.g., gestonorone caproate) or are used in new preparations for contraception and hormone therapy (e.g., trimegestone, nomegestrol acetate, nesterone) (Fig. 2).

In 1951, norethisterone acetate was synthesized by Junkmann and Schenk at Schering, and norethynodrel by Frank D. Colton at Searle. Dimethisterone that was developed in 1957 in England, was a relatively weak progestogen and was used in the first sequential oral contraceptives. Like other progestins used in oral contraceptives during the first years after the introduction of the pill, dimethisterone disappeared from the market (Fig. 3).

Lynestrenol and ethynodiol diacetate that are norethisterone-prodrugs like norethynodrel, and D,L-norgestrel were developed in the 1960s.

The first progesterone derivatives were 17 α -acetoxyprogesterone (1954 by Karl Junkmann at Schering), medroxyprogesterone acetate (1957 at Syntex), megestrol acetate (1959 at Syntex), and chlormadinone acetate (1959 at Syntex)

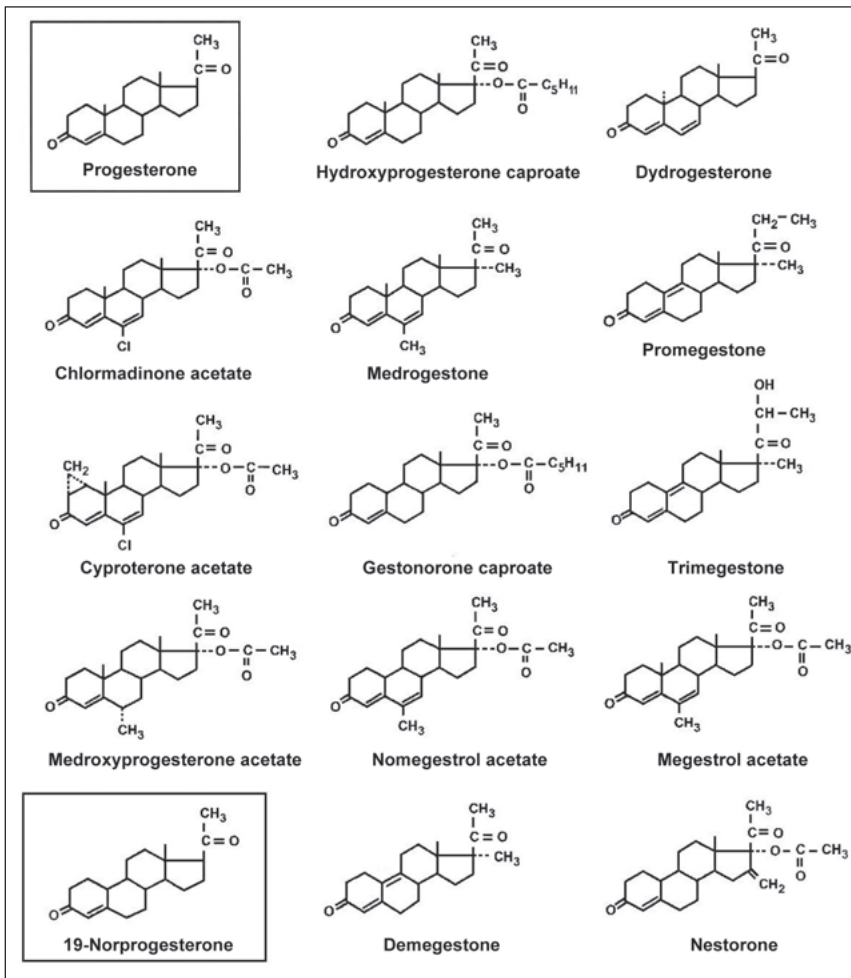

Figure 2. Structural formulae of progesterone derivatives and 19-norprogesterone derivatives.

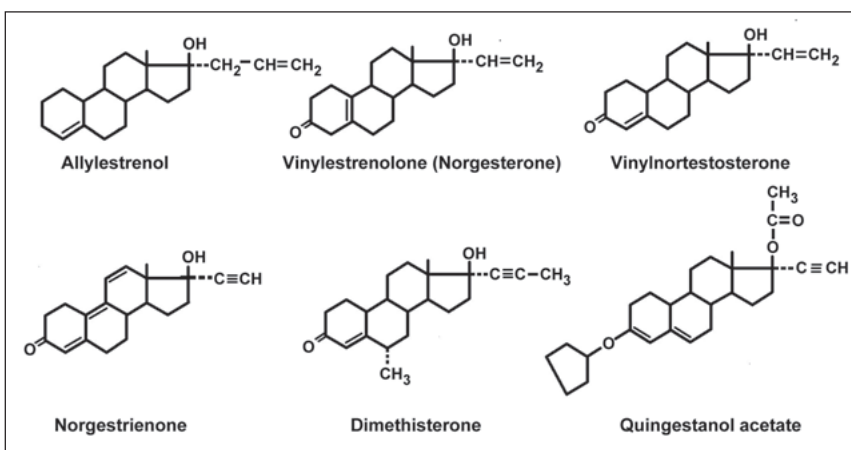

Figure 3. Structural formulae of formerly used progestins.

(Fig. 2). The retroprogesterone derivative dydrogesterone was synthesized in 1959 at Philips-Duphar, and cyproterone acetate in 1961 by Rudolf Wiechert at Schering (Fig. 2).

Desogestrel was synthesized in 1972 at Organon, dienogest in 1978 by Hübner and Ponsold at Jenapharm.

Mechanism of Action

The primary target organ of progestogens is the endometrium, and the evaluation and comparison of activities and potencies of synthetic progestins mostly refer to clinical or in vitro tests with endometrial end-points.

The various actions of progesterone and synthetic progestins are brought about by genomic interactions with the progesterone receptors (PRs) which exist in the two isoforms PRA and PRB, and by rapid non-genomic interactions with binding sites at the membrane that can activate, e.g., cross-talk mechanisms with other signal transduction pathways. Moreover, according to their chemical structure, progestogens may bind to other members of the nuclear receptor superfamily, e.g. androgen receptor, glucocorticoid receptor, and mineralocorticoid receptor, and may act as agonists or antagonists. Therefore, according to their structure the various progestogens may differ in their pattern of hormonal activities.

Binding of a progestogen to the receptor protein causes a specific conformational change which depends on the chemical structure of the steroid. The receptor-steroid complex dimerizes and, interfering with various other transcription factors, interacts with promoters containing progestogen responsive elements within hormone-regulated target genes. Irrespective of the affinity, the binding of a progestogen to the receptor may either induce agonistic or antagonistic effects. This depends on the conformation of the steroid-receptor complex that facilitates an interaction with co-activators or co-repressors resulting in either an increase or a decrease of transcriptional activity.

In general, PRA may act as transcriptional repressor and PRB as activator. PRA may repress not only the transcriptional activity of the PRB, but also that of the estrogen receptor (ER), androgen receptor, the glucocorticoid and mineralocorticoid receptors [16].

In most tissues, the biological action of progestogens is dependent on the presence of estrogens, as estrogens play a key role in the induction of PR. In the follicular phase, binding of estradiol to ER α causes an upregulation of PRA and PRB in the endometrial glandular epithelium, while in endometrial stroma the expression of PRB is higher than that of PRA. Both PRA and PRB are moderately expressed in perivascular cells, whereas in the vascular endothelium no expression of both receptors occurs [17, 18].

Both the progestogen-induced transcription and secretory differentiation in an

estrogen-primed endometrial epithelium as well as the proliferation and differentiation of stroma are mediated by PRB.

During the luteal phase, progesterone suppresses the expression of epithelial and stromal ER α and ER β in the endometrial functionalis, but not in the basalis. This reduction of the ER and the inhibition of the estrogen-dependent proliferation of the epithelium are mediated by the PRA [19, 20]. Similarly, the progestogen-induced downregulation of PRA and PRB in the glandular epithelium, and the suppression of the androgen receptor in endometrial stroma are mediated by PRA [20].

As the progestogen-induced suppression of the PR occurs only in the endometrial glandular epithelium, but not in the stroma and myometrium, the progestogenic effects in the endometrium during the luteal phase may be induced by stromal PR [18, 20].

In the breast of primates, progestogens may reduce the expression of the ER α and PR, but the estrogen-induced proliferation of the mammary epithelium is not inhibited, but enhanced by progestogens [21]. Epithelial cells of the breast containing PR do not proliferate.

The primary role of progestogens in HRT is the inhibition of estrogen-induced proliferation of the endometrium. Moreover, they induce secretory changes in a proliferated endometrium. The anti-estrogenic effect of progestogens in the endometrium is associated with a suppression of ER and the activation of the 17 β -hydroxysteroid dehydrogenase type 2 (17HSD2) which converts estradiol to estrone, and of the estrone-sulfotransferase which causes conjugation of estrone.

The activation of the 17HSD2 by progestogens is regulated by paracrine mechanisms. Binding of progestogens to PRB in endometrial stromal cells induces the release of paracrine factors that stimulate the synthesis of transcription factors SP1 and SP2 in endometrial epithelial cells. Both activate the expression of 17HSD2 in the endometrial epithelium [22, 23]. Owing to a deficiency of PRB in stromal cells progestogens cannot induce the expression of 17HSD2 in endometriotic cells. There-

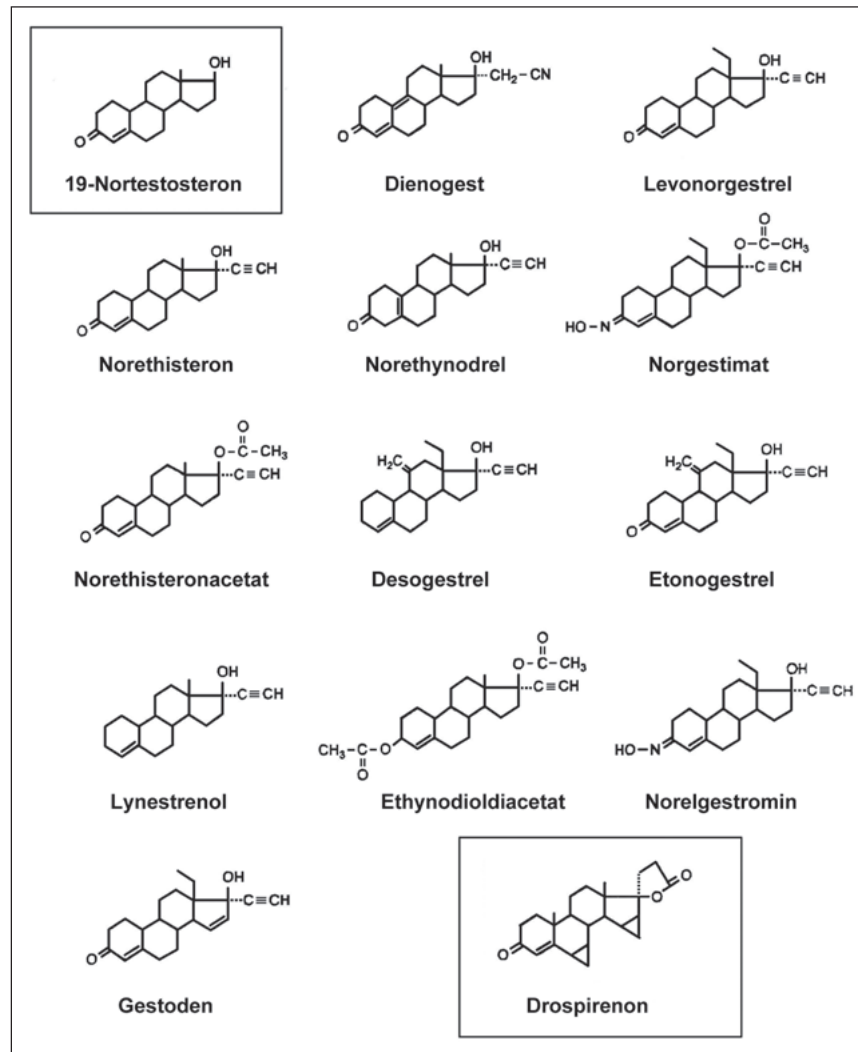

Figure 4. Structural formulae of 19-nortestosterone derivatives and of the spirolactone derivative drospirenone.

fore, endometriosis is characterized by a pronounced estrogen-induced proliferation because the inactivation of estradiol is defective [24].

■ Structure, Activity and Metabolism of Progestogens

Besides the natural progesterone, four types of orally active, synthetic progestins are available: the progesterone derivatives and 19-norprogesterone derivatives (Fig. 2), 19-nortestosterone derivatives and the spirolactone derivative drospirenone (Fig. 4). They all exert progestogenic and – in some tissues – antiestrogenic activities, but differ largely in their hormonal pattern. According to their chemical structure, they may act as weak androgens or antiandrogens, glucocorticoids or antiminerocorticoids (Tab. 1). This is based on the

structural similarity of the respective receptors which belong to the nuclear receptor superfamily. The various progestogens may bind to one or more of these receptors with low or high binding affinity, but there is not necessarily a corresponding biologic response (Tab. 2). Binding to a receptor may be associated with an agonistic, antagonistic or no clinical effect (Tab. 1, 2).

The prerequisite of the progestogenic activity of a steroid is the existence of a 3-keto group and a double-bond between C4 and C5 in the A-ring (Δ^4 -3-keto group). There are some nortestosterone derivatives that lack this characteristic, e.g., norethynodrel, lynestrenol, desogestrel, norgestimate (NGM) or tibolone (TIB). They are prodrugs that after oral administration are rapidly converted to an active progestin with a Δ^4 -3-keto group (Fig. 5, 6).

Table 1. Patterns of hormonal activities of progestogens [1].

Progestogen	A-E	EST	AND	A-A	GLU	A-M
Progesterone	+	-	-	(+)	+	+
Chlormadinone acetate	+	-	-	+	+	-
Cyproterone acetate	+	-	-	+	+	-
Medroxyprogesterone acetate	+	-	(+)	-	+	-
Medrogestone	+	-	-	-	?	-
Dydrogesterone	+	-	-	-	?	(+)
Norethisterone	+	+	+	-	-	-
Levonorgestrel	+	-	+	-	-	-
Gestodene	+	-	+	-	(+)	+
Etonogestrel (3-keto-desogestrel)	+	-	+	-	(+)	-
Norgestimate	+	-	+	-	?	?
Dienogest	+	-	-	+	-	-
Tibolone metabolites	+	+	++	-	-	-
Drospirenone	+	-	-	+	-	+
Trimegestone	+	-	-	(+)	-	(+)
Promegestone	+	-	-	-	+	-
Nomegestrol acetate	+	-	-	+	-	-
Nestorone	+	-	-	-	-	-

The data are mainly based on animal experiments and are compiled from the literature [17, 25–34].

The clinical effects of the progestogens are dependent on their tissue concentrations.

A-E: antiestrogenic; EST: estrogenic; AND: androgenic; A-A: antiandrogenic; GLU: glucocorticoid; A-M: antimineralocorticoid activity; ++: strongly effective; +: effective; (+): weakly effective; -: not effective; ?: unknown

Table 2. Relative binding affinities to steroid receptors and serum binding globulins of progestogens [1].

Progestogen	PR	AR	ER	GR	MR	SHBG	CBG
Progesterone	50	0	0	10	100	0	36
Chlormadinone acetate	67	5	0	8	0	0	0
Cyproterone acetate	90	6	0	6	8	0	0
Medroxyprogesterone acetate	115	5	0	29	160	0	0
Medrogestone							
Dydrogesterone	75						
Norethisterone	75	15	0	0	0	16	0
Levonorgestrel	150	45	0	1	75	50	0
Gestodene	90	85	0	27	290	40	0
Etonogestrel (3-keto-desogestrel)	150	20	0	14	0	15	0
Norgestimate	15	0	0	1	0	0	0
Dienogest	5	10	0	1	0	0	0
Δ -4-Tibolone (7 α -methyl-norethisterone)	90	35	1	0	2	1	0
Drospirenone	25	2	0	6	230	0	0
Trimegestone	330	1	0	9	120		
Promegestone	100	0	0	5	53	0	0
Nomegestrol acetate	125	42	0	6	0	0	0
Nestorone	136	0	0	38		0	

PR: progesterone receptor (promegestone, 100%); AR: androgenreceptor (metribolone R1881, 100%); ER: estrogen receptor (estradiol-17 β , 100%); GR: glucocorticoid receptor (dexamethasone, 100%); MR: mineralocorticoid receptor (aldosterone, 100%); SHBG: sex hormone-binding globulin (dihydrotestosterone, 100%); CBG: corticosteroid-binding globulin (cortisol, 100%).

The values were compiled from the literature by cross-comparisons [29, 31, 35–38]. As the results of the various in vitro-experiments are largely dependent on the incubation conditions and biological materials used, the values are inconsistent. They do not necessarily reflect the biological effectiveness.

Besides their effect on the endometrium, synthetic progestins may act on the vaginal epithelium as antiestrogens and reduce the maturation index. In the cervix progestins reduce the amount and “spinnbarkeit” of the mucus, in the oviducts they control motility and composition of fluid, and in the breast they enhance estrogen-induced proliferation of mammary epithelium. Except dydrogesterone, the progestogens may influence CNS function and psyche, inhibit gonadotropin release, increase body temperature, and antagonize various central effects of estrogens. Progestogens influence directly the function of the vessel wall: in arteries they exert a constrictory effect and antagonize the dilatory action of estrogens, whereas in veins they enhance the dilatory effect of estrogens, and increase the vascular distensibility.

Progestins with antiandrogenic activity, e.g., cyproterone acetate (CPA), dienogest (DNG), chlormadinone acetate (CMA) or DRSP, may reduce the effects of endogenous androgens, whereas those with androgenic properties, e.g., LNG, NET or TIB, may cause androgenic effects on the skin and hair, and may antagonize certain estrogen-dependent alterations in lipid metabolism, hemostasis and the synthesis of certain hepatic proteins (e.g., SHBG, TBG, angiotensinogen). Progestogens with glucocorticoid activity may reduce ACTH secretion at higher concentrations or exert glucocorticoid effects on the vessel wall or immune system at the usual concentrations. Some progestogens, e.g. progesterone and drospirenone, may act as an aldosterone antagonist which is accompanied by a compensatory rise in the aldosterone levels. Progestogens may also impair glucose tolerance and cause a slight hyperinsulinemia.

Due to their antiestrogenic effect, progestogens including progesterone may counteract the stimulatory and excitatory effects of estrogens on the brain. Beyond this, progesterone exerts a pronounced sedative effect after conversion to 5 α - and 5 β -pregnanolone which bind to the GABA_A-receptor. The receptor binding affinity and hormonal activity of metabolites of some synthetic progestins have also been investigated. It is known that 3 α -hydroxy-CMA and 15 β -hydroxy-CPA exert a pronounced anti-

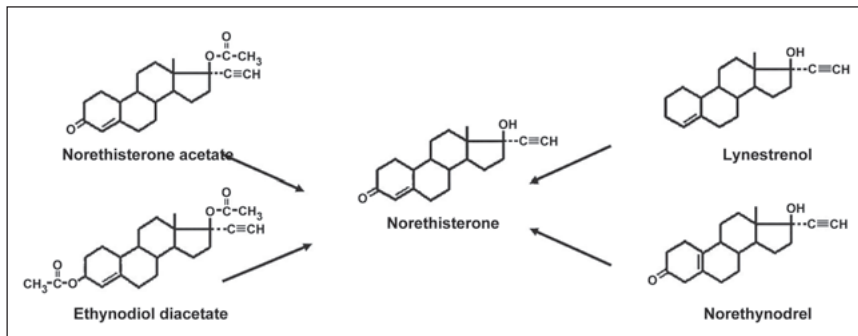

Figure 5. Conversion of prodrugs of norethisterone to the active progestin norethisterone.

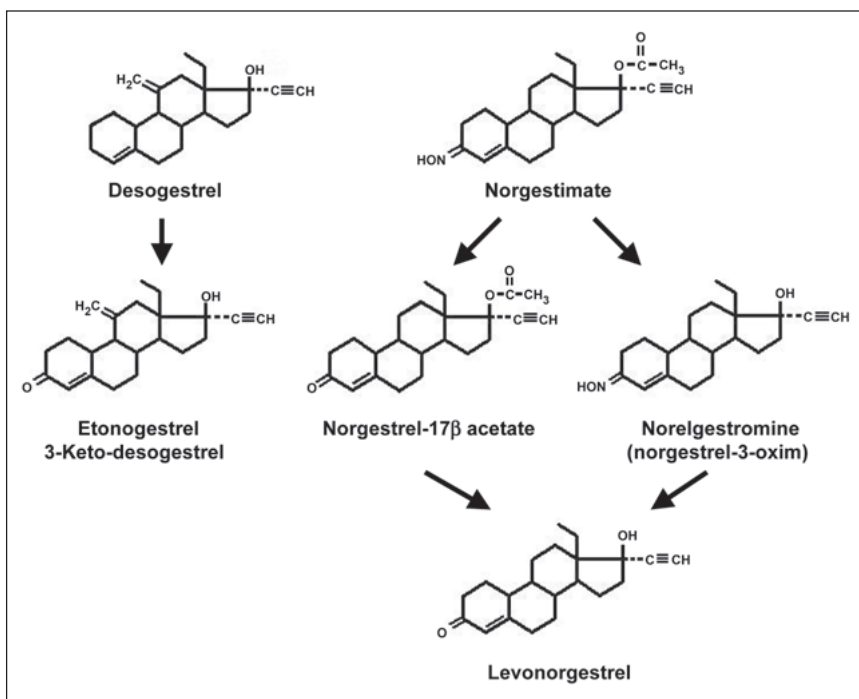

Figure 6. Conversion of the prodrugs desogestrel and norgestimate to the active progestins etonogestrel and levonorgestrel.

androgenic effect. Some reduced metabolites of the nortestosterone derivatives show some antiandrogenic or androgenic effects, or even a slight estrogenic activity [17].

Potency of Progestogens

During the early 1960s numerous nortestosterone derivatives and progesterone derivatives were available that differed not only in their hormonal pattern, but also in their potency. Therefore, the choice of an optimal dose for therapeutic or contraceptive use was difficult. For dose finding, animal experiments were not very helpful, because the potency of sex steroids is largely influenced by the metabolism after oral administration. The aim of the various assays was to compare the efficacy of the compounds with respect to contraceptive action,

cycle control and side-effects. The most frequently used method for expressing the progestogenic potency of a pill was to multiply the total dose of a progestogen component by its comparative progestogenic activity evaluated in a suitable assay [39].

However, most of the methods used for the determination of the activity of progestins related to the effect on the endometrium of women, and one assay, the glycogen deposition test, was an *in vitro* assay [39–43]:

- Delay of menses
- Transformation dose
- Induction of hormone withdrawal bleeding
- Glycogen deposition in endometrial glands
- Depression of karyopyknotic index in the vagina

- Inhibition of estrogen effect on cervical mucus

The glycogen deposition is measured *in vitro* using cultured human endometrial tissue obtained from women in the follicular phase [39, 42]. The assay allows a good standardization and the evaluation of weak progestogens, but is not suitable for the investigation of prodrugs and cannot be extrapolated to the oral route of administration.

The delay of menses test is carried out in women with regular cycles who are treated daily with 50 µg EE and a constant dose of the progestogen for 20 days starting on Day 6 or 7 after the supposed ovulation. The test is positive if menses is postponed, and in subsequent trials the lowest effective dose of the progestin is determined (Tab. 3) [40, 43, 44].

The transformation dose (TFD) reflects the typical PR-mediated progestogenic effect in the endometrium. The TFD was evaluated in ovariectomized women who were treated orally with 50 µg EE per day for 14 days and thereafter with EE and a certain dose of a progestin for 10 days. The TFD of a progestogen was that daily dose which causes full secretory transformation of the proliferated endometrium [41]. As the inhibitory effect of progestogens in an endometrium under treatment with EE needs a higher dose than with estradiol, the results cannot be extrapolated to hormone replacement therapy.

The high transformation dose of progesterone reflects the low oral bioavailability owing to a rapid inactivation. The relatively high transformation dose of NET and NETA can be explained by the aromatization of a small proportion of NET to EE which antagonizes the progestogenic effect of NET in the endometrium (Tab. 3) [25, 45].

The potency of the various progestogens is tissue-specific and, therefore, the data cannot be generalized. Moreover, it must be emphasized that the results of various clinical trials differ largely. The clinical relevance of the various assays is relatively low, as, e.g., the transformation doses do not correlate with the results of the delay of menses test or the glycogen deposition assay (Tab. 3). The discrepancies between data determined in the

Table 3. Results of assays for comparison of potencies of progestogens [39–43].

Progestogen	Transformation dose (Dose)	Glycogen deposition (Potency)	Delay of menses (Potency)
Progesterone		100%	
Ethinodiol diacetate	10 mg	120%	2000%
Levonorgestrel	12 mg	560%	4000%
Chlormadinone acetate	30 mg		200%
Medroxyprogesterone acetate	30 mg	810%	100%
Norethisterone acetate	50 mg	560%	270%
Norethisterone	120 mg	650%	130%
Lynestrenol	150 mg		270%

Table 4. Hormonal potency of progestogens and daily doses contained in available preparations [1, 25, 41, 49, 53].

Progestin	TFD (mg/Cycle)	OID (mg/Day)	ODP (mg/Day)
Progesterone	4200	300	
Medroxyprogesterone acetate	50		
Megestrol acetate	50		
Chlormadinone acetate	25	1.7	2.0
Cyproterone acetate	20	1.0	2.0
Dienogest	6	1.0	2.0–3.0
Tibolone		2.5	
Norethisterone	120	0.4	0.5
Norethisterone acetate	50	0.5	0.6
Norgestimate	7	0.2	0.25
Levonorgestrel	5	0.06	0.1–0.15
Desogestrel/3-keto-desogestrel	2	0.06	0.15
Gestodene	3	0.04	0.06–0.075
Drospirenone	50	2.0	3.0
Nomegestrol acetate	100	1.25	2.5
Promegestone	10	0.5	

TFD: transformation dose in women; OID: ovulation-inhibiting dose in women (without additional estrogen); ODP: oral dose contained in available preparations

same target organ suggest that the value of the results is largely questionable if they will be used as a measure for ovulation inhibition, the effect on breast tissue or the hepatic metabolism.

The ovulation-inhibiting dose (OID) is evaluated in ovulatory women who are treated daily with a certain dose of a progestogen between cycle day 5 and 25. The lowest dose which inhibits ovulation in all women, is the OID. It must be kept in mind that the data of most progestogens are evaluated in relatively few subjects. The ovulation inhibition is brought about by a complex mechanism including not only the disturbance of FSH and LH secretion at the hypothalamic and pituitary level and the inhibition of the preovulatory LH peak, but also by direct interactions of the pro-

gestogens with ovarian functions. Synthetic progestogens may cause a direct inhibition of the ovarian steroid biosynthesis which is more pronounced using compounds with an ethinyl group. After oxidative activation of the 17 α -ethinyl group, nortestosterone derivatives may not only inhibit irreversibly CYP-dependent oxygenases which are involved in the hepatic inactivation of steroid hormones, but may also inhibit ovarian CYP enzymes which play a role in the biosynthesis of endogenous steroids [46–52]. This may explain the discrepancy between DNG and LNG or gestodene (GSD) regarding their potency. Similar to LNG and GSD, DNG showed a high endometrial efficacy as reflected by a low TFD, but has a relatively weak ovulation-inhibiting potency due to the lack of a 17 α -ethinyl group (Tab. 4).

The contraceptive reliability of a preparation can be estimated by comparing the OID with the dose of the progestin contained in the pill (Tab. 4).

■ Progesterone

Progesterone is an important intermediate in the ovarian and adrenal steroid synthesis, but larger amounts are produced only in the corpus luteum and the placenta. During the luteal phase, serum concentrations of 25 ng/ml are reached which may increase during pregnancy up to 200 ng/ml. In the human, progesterone is the only progestogen which is able to maintain pregnancy. In the endometrium and cervix, it exerts strong progestogenic and antiestrogenic activities; it has a pronounced antimineralocorticoid effect which causes a compensatory rise in the aldosterone levels by 70%, and exerts an “antiandrogenic” effect which is not associated with binding to the androgen receptor, but a competitive inhibition of the 5 α -reductase activity in the skin.

About 17% of the circulating progesterone is bound with high affinity to CBG and 80% with low affinity to albumin. Despite this, the half-lives are only 6 min ($t_{1/2\alpha}$) and 42 min ($t_{1/2\beta}$). Progesterone is rapidly metabolised, predominantly by reduction of the keto groups and the Δ^4 -double bond, and the pattern of metabolites depends largely on the route of administration.

The oral application of progesterone is associated with an extensive metabolism in the gastrointestinal tract and the liver which results in high, but individually variable concentrations of circulating metabolites. Consequently, the investigation of the pharmacokinetics of progesterone by means of RIA may be hampered by falsely high progesterone levels due to a relatively pronounced cross-reactivity of progesterone metabolites. Therefore, either the GC/MS method or radioimmunoassay (RIA) after chromatographic separation are suitable for the measurement of progesterone. This problem is less pronounced after vaginal administration of progesterone owing to the relatively low degree of metabolism [54].

Oral Administration

After oral administration, progesterone can be metabolised to more than 30 me-

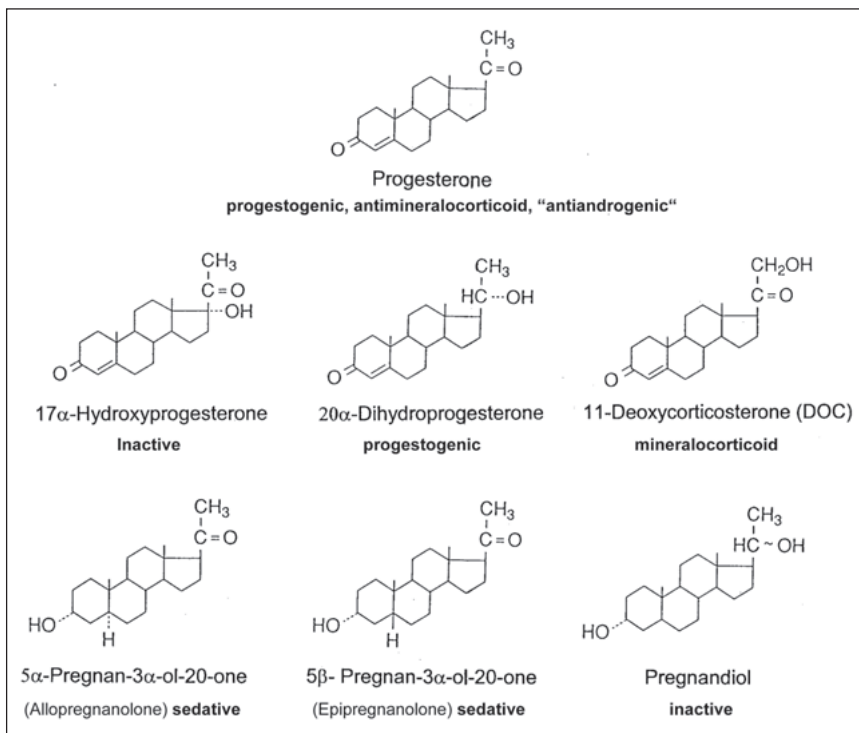

Figure 7. Structural formulae of progesterone and some progesterone metabolites.

tabolites, among which some exert specific physiological activities. The most important pathway is the formation of 5 α -pregnanolone and 5 β -pregnanolone that exert considerable sedative effects after binding to the GABA_A receptor. Further metabolites were 20-dihydroprogesterone that has 25–50% of the progestogenic potency of progesterone, 11-deoxycorticosterone (DOC) that is a potent mineralocorticoid, 17 α -hydroxyprogesterone, and the inactive end-product pregnanediol (Fig. 7).

There are large interindividual differences in the pattern of metabolites circulating after oral administration [55]. The low oral bioavailability could be increased by the use of micronized progesterone suspended in oil and packaged in a gelatine capsule.

Pharmacokinetics

A single oral dose of 100 mg progesterone contained in a gelatine capsule led to a rapid rise in serum progesterone as measured by liquid chromatography/mass spectrometry to a peak level of 1.5–2.2 ng/ml after 1–2 h. Thereafter the levels decreased rapidly to baseline levels within 4–6 h [53, 55]. However, determination by means of RIA revealed a mean peak level of 19.4 ng/ml suggesting a high cross reaction of progesterone meta-

bolites [54]. There was a pronounced rise in the serum levels of 5 α - and 5 β -pregnanolone up to a maximum of 14 ng/ml and 3.6 ng/ml after 2 h. The DOC levels rose from 120 pg/ml to 680 pg/ml after 2 h and decreased rapidly thereafter [56].

The results cast some doubts on the reliability of progesterone determinations by RIA if metabolites are not separated by means of chromatographically in advance.

After oral intake of 200 mg progesterone, the peak levels of progesterone as measured by RIA after 4 h were 12 ng/ml, while 5 α - and 5 β -pregnanolone reached serum concentrations of 30 ng/ml and 60 ng/ml [55]. Further metabolites were 20-dihydroprogesterone, DOC, 17 α -hydroxyprogesterone, and pregnanediol (Fig. 7).

Pharmacodynamics

The results of a large prospective study indicate that oral and transdermal treatment with progesterone does not protect from estrogen-induced endometrial cancer in postmenopausal women. Compared with women treated with estrogen-only preparations who showed an elevated relative risk of 2.52 (95%-CI: 1.77–3.57), the risk of endometrial cancer did not differ significantly during

therapy with estrogen plus progesterone (relative risk 2.42; 95%-CI: 1.53–3.83). Contrary to this, synthetic progestogens reduced the estrogen-dependent risk significantly [57]. The lack of endometrial protection during oral progesterone therapy may be explained by the low progesterone serum levels measured with reliable methods. The same phenomenon may also explain the results of another cohort study that, in contrast to synthetic progestins, the addition of progesterone to estrogen therapy did not increase the risk of breast cancer [58, 59].

The finding of an elevated risk of endometrial cancer in postmenopausal women during treatment with estrogens and oral progesterone are in contradiction to various trials that did not find any increase in the rate of endometrial hyperplasia in women treated with estrogens and 200 mg sequential progesterone or 100 mg continuous progesterone [60–62]. However, the effect of oral treatment with progesterone on estrogenized postmenopausal endometria is dose-dependent, and during the use of 200 mg no full secretory transformation was observed, whereas the daily dose of 300 mg seems to be appropriate as an alternative to synthetic progestogens for therapy [63].

The PEPI trial revealed that the favourable effects of estrogens on lipid metabolism are preserved when progesterone is added orally [64]. Oral treatment with 100 to 300 mg progesterone led to a dose-dependent decrease in blood pressure [65]. Moreover, progesterone enhances the ventilatory response to CO₂ in the luteal phase and during pregnancy. It has also been demonstrated that progesterone derivatives like chlormadinone acetate may cause a reduction in arterial CO₂ tension [66].

The two A-Ring-reduced metabolites, allopregnanolone (5 α -pregnanolone) and epipregnanolone (5 β -pregnanolone) may modulate GABA_A-receptors and exert a concentration-dependent bimodal effect on the CNS. High concentrations of allopregnanolone have been shown to cause anxiolytic, sedative, anaesthetic and anti-epileptic effects, while low physiological concentrations may act anxiogenic [5]. The symptoms of the premenstrual dysphoric disorder seem to be associated with a change of receptor sensitivity to

GABA_A-modulators. There is also evidence that allopregnanolone may impair learning and memory [67].

Using single oral doses between 300 and 1200 mg, a significant increase in fatigue and a decrease in vigour was recorded. With the highest dose, some women showed a reduced information processing and verbal memory function [68]. The oral use of 200 mg progesterone resulted in a higher incidence of drowsiness and dizziness, although the drugs were taken at bedtime [62]. In a patient who ingested 400 mg micronized progesterone, a hypnotic state was induced that lasted for 2 h. In this woman, very high levels of 5 α - and 5 β -pregnanolone could be measured [55].

Vaginal Administration

In contrast to the oral route of administration, the rate of metabolism and the formation of pregnanolones are much lower during vaginal treatment with progesterone. Therefore, the risk of a sedative effect of progesterone is lower than that observed during oral therapy.

Pharmacokinetics

Compared with the oral route, the vaginal route of administration of progesterone results in higher serum levels of progesterone which are maintained for a longer period of time than after oral treatment. The slow elimination of progesterone might be associated with a direct vagina-to-uterus transport by diffusion (uterine first pass) resulting in a high storage of progesterone in the uterus and a subsequent delayed release of the progestogen [69, 70]. Using an ex-vivo uterine perfusion model, concentrations of 185 \pm 155 ng/100 mg endometrial tissue and 254 \pm 305 ng/100 mg myometrial tissue were measured [69].

A single vaginal application of a gelatine capsule with 100 mg or 200 mg progesterone led to a rapid rise in serum progesterone up to a maximum of about 5 ng/ml after 6–12 h. Thereafter, the concentrations remained at this level for 24 h and were still above baseline levels after 72 h [56, 71]. Among the metabolites, 5 α -pregnanolone reached a peak level of 3.5 ng/ml after 2 h, whereas 5 β -pregnanolone did not change. The DOC levels differed individually, and a rise from 30 to 100 pg/ml was observed after 4 h only in some of the women

[56]. A vaginal suppository containing 400 mg progesterone resulted in mean peak levels of 16 ng/ml progesterone after 5 h [72].

A vaginal gel consisting of a water-in-oil emulsion with polycarbophil which contains either 45 mg (4%) or 90 mg (8%) micronized progesterone, has bioadhesive properties and releases progesterone in a sustained manner [73]. A single dose of 90 mg progesterone resulted in a rise of the progesterone level to a maximum of 10 ng/ml after about 8 h. Thereafter the levels declined to 3 ng/ml after 24 h [54].

In estrogen-treated postmenopausal women, the progesterone levels may be lower due to an enhanced metabolism in the estrogen-induced proliferated vaginal epithelium. In patients treated with 100 μ g transdermal estradiol, the sequential vaginal treatment with a gel containing 45 mg, 90 mg or 180 mg progesterone every other day resulted in peak serum concentrations of progesterone of approximately 4 ng/ml, 6 ng/ml and 7.5 ng/ml after 7 h [73].

The insertion of a vaginal ring releasing daily 10 mg progesterone into estrogen-treated postmenopausal women resulted in maximal progesterone levels of about 15 ng/ml after 24 h. Thereafter, serum progesterone decreased slowly during the following weeks reaching concentrations of about 2 ng/ml after 12 weeks [74]. During the first week of use of this vaginal ring for contraception in lactating women maximal serum concentrations of about 11 ng/ml were measured which declined to 8 ng/ml, 5 ng/ml and 3 ng/ml after 4, 9 and 16 weeks [75].

Pharmacodynamics

In postmenopausal women treated with 100 μ g transdermal estradiol, the sequential vaginal treatment with a gel containing 45 mg, 90 mg or 180 mg progesterone every other day from day 15–27 induced in all patients a full secretory transformation of the endometrium [73]. Similarly, in postmenopausal women treated continuously with 0.625 mg CEE for 3 cycles, cyclic treatment with a vaginal gel containing 45 mg or 90 mg progesterone between day 17 and 27 every other day, caused a secretory or atrophic endometrium and prevented endometrial hyperplasia in all women [76].

The high efficacy supports the thesis of a direct transport to the uterus of vaginally applied progesterone. The most frequent side-effects were fatigue and weakness [71].

An effective protection of the endometrium in postmenopausal women treated with transdermal estradiol was brought about by vaginal rings releasing daily 5 mg or 10 mg progesterone [74].

Intranasal Administration

As progesterone is lipophilic, sufficient doses can be applied using a suspension of progesterone in almond oil with a bioavailability of 18%. After intranasal spraying of 11.2 mg progesterone contained in 0.55 ml almond oil, peak levels of serum progesterone of 3.75 ng/ml were reached within 1 h; after a transitory decline a second peak of 2.7 ng/ml occurred after 4 h [77]. Intranasal treatment with 11.2 mg progesterone three times daily resulted in a progressive increase in the progesterone serum levels up to 6 ng/ml. The endometrial histology revealed a suppressed or late secretory pattern [77].

Similar to estradiol, a sufficient increase in the solubility of progesterone was achieved using methylated cyclodextrin which is highly hydrophilic but can bind steroids. In this way the bioavailability of intranasally administered progesterone was increased to 58%. The intranasal co-administration of 5 mg progesterone and 2 mg estradiol, solubilized by complexing with methylated cyclodextrin caused maximal serum concentrations of progesterone between 3.9 and 6.7 ng/ml within 15–40 min [77].

Intramuscular Administration

A single intramuscular injection of 100 mg progesterone in an oily solution resulted in a rapid increase in the serum levels of progesterone up to a maximum between 40 and 80 ng/ml after 8 h. Thereafter, the levels declined continuously to about 6 ng/ml after 48 h. The maximal serum concentrations of 20-dihydroprogesterone were between 4 and 16 ng/ml, and of 17 α -hydroxyprogesterone between 0.8 and 2.7 ng/ml [78].

Transdermal Administration

There are several studies on the transdermal use of progesterone. As the serum levels of progesterone achieved by

this route of administration were much lower than those measured in the luteal phase, a protective effect on the endometrium must be called in question [79].

The daily administration of a cream containing 30 to 40 mg progesterone on an area of 100 cm² of the forearm skin of postmenopausal women resulted in a small rise in the serum progesterone levels reaching about 1 ng/ml or less after 6 or 48 weeks of treatment [80–84].

As progesterone is a lipophilic steroid, it has been suggested that it is taken up by erythrocytes and transported by these vehicles in the circulation. However, no elevated concentrations of progesterone could be found in the red blood cells of postmenopausal women during treatment with progesterone cream [82].

Studies on the effect of progesterone cream on vasomotor symptoms revealed contradictory results [84, 85]. A suppression of estrogen-induced endometrial proliferation observed during treatment with progesterone cream remains to be confirmed [86].

■ Progesterone Derivatives

The introduction of substituents into the steroid skeleton which sterically hinder from the action of metabolising enzymes, resulted in a considerable slowing down of the inactivation rate and in an increase in the hormonal potency (Fig. 2). A methyl group or chloro atom at C6 reduces or blocks the reduction of the Δ^4 -3-keto group, and influences the interaction with the androgen receptor. Whereas a chloro atom at C6 β causes antiandrogenic properties of the progestin, a methyl group at C6 leads to a weak androgenic activity. An acetyl group or a methyl group at C17 α inhibits the reduction of the 20-keto group of progesterone. In contrast to the 17 α -esters, 17 α -hydroxy-progesterone has no hormonal activity.

If no chromatographic separation is carried out, the measurement of the serum levels of progesterone derivatives by means of RIA may lead to falsely high serum concentrations, owing to the presence of metabolites which interact with the antibody. Therefore, the use of the GC/MS method revealed much lower levels than previously published.

Table 5. Relative binding affinity (RBA) to the glucocorticoid receptor of various steroid hormones and their in vitro-effect on the expression of the thrombin receptor in vascular smooth muscle cells [1, 28].

Steroid hormone	Upregulation of the thrombin receptor	RBA to glucocorticoid receptor
Dexamethasone	++	100%
Medroxyprogesterone acetate	+	29%
Gestodene	+	27%
3-Keto-desogestrel	+	14%
Progesterone	+	10%
Levonorgestrel	–	1%
Norgestimate	–	1%
Norethisterone	–	0%
Ethinylestradiol	–	0%

–: no effect; +: pronounced effect; ++: strong effect

Medroxyprogesterone Acetate (MPA)

Pharmacokinetics

MPA does not undergo a first-pass inactivation after oral administration, and the bioavailability is 100%. Treatment of postmenopausal women for 2 weeks with 1 mg or 2 mg estradiol valerate and 2.5 mg or 5 mg MPA per day resulted in a rapid increase in the serum levels of MPA up to maximum serum concentrations within 1.5 and 2 h. Using 2.5 mg MPA, the mean peak levels were 0.3 ng/ml in the age group < 60 years and 0.45 ng/ml in women > 65 years, and using 5 mg MPA 0.6 ng/ml and 0.9 ng/ml, respectively [87]. During daily intake, a steady-state is reached after 3 days of treatment.

In the circulation, 88% of MPA is bound to albumin, but not to SHBG or CBG. MPA is to a certain extent stored in fat tissue. The half-lives are 2.2 h (t_{1/2 α}) and 33 h (t_{1/2 β}). The main metabolic steps are hydroxylation reactions, e.g., at C6 β and C21, with the preservation of the Δ^4 -3-keto group, but there are also dihydro-derivatives and tetrahydro-derivatives of MPA [17].

Pharmacodynamics

MPA antagonizes the estrogen-induced endometrial proliferation. In general, daily doses of 5–10 mg are sufficient for the prevention of endometrial hyperplasia in postmenopausal women during sequential or cyclic HRT, while 2.5 mg MPA have been shown to be protective during continuous combined HRT. Despite a binding affinity to the aldosterone receptor, MPA has no mineralocorticoid or antimineralocorticoid activity.

It was, however, demonstrated that MPA exerts considerable glucocorticoid effects mediated by binding to the glucocorticoid receptor. At physiological concentrations it caused an upregulation of the thrombin receptor and stimulates the procoagulatory activity in the vessel wall (Tab. 5) [28]. Weekly intramuscular injections of 1200 mg MPA significantly reduced ACTH release and the plasma levels of cortisol by 75% [88]. Long-term treatment of a patient with daily 400 mg MPA led to the induction of the Cushing syndrome [89]. On the other hand, in asthma patients treated chronically with 10–20 mg prednisolone per day, intramuscular injections of 200 mg MPA every 6 weeks reversed the progression of glucocorticoid-induced osteoporosis by competitive antagonism at the glucocorticoid receptor level [90]. MPA might also be a candidate for the treatment of autoimmune/inflammatory disease [91].

MPA has no antiandrogenic effect, but weak androgenic properties. Although MPA does not antagonize the estrogen-induced rise in triglycerides and HDL-CH, treatment with depot-MPA every second week may reduce HDL [17]. At doses of 10 mg daily, MPA causes an impairment of glucose tolerance without affecting lipid metabolism [92]. In women with contraindication for estrogens who suffer from vasomotor symptoms, daily treatment with 20 to 40 mg MPA may improve the complaints.

Megestrol Acetate (MGA)

According to structural similarities, the hormonal pattern of MGA is similar to

that of MPA (Fig. 2, Tab. 1). Three h after oral administration of 4 mg MGA a maximal serum concentration of MGA of about 7 ng/ml was measured. The bioavailability is 100% and the majority of MGA in the circulation is bound to albumin, because it has no binding affinity to SHBG or CBG. The main metabolic pathways are hydroxylation reactions at C-21, C2a, and C6.

Similar to MPA, MGA has been shown to improve vasomotoric symptoms at doses of 20–40 mg [93]. It also exerts considerable glucocorticoid activity, and in cancer patients treated with high doses of MGA, cases of Cushing syndrome, new-onset diabetes or exacerbation of pre-existing diabetes, and adrenal insufficiency have been reported [94]. Continuous combined therapy of postmenopausal women with 2 mg estradiol and 5 mg MGA resulted in a reduction of HDL-CH and LDL-CH and no effect on triglycerides indicating a moderate androgenic activity of MGA [95].

Chlormadinone Acetate (CMA)

In contrast to MPA and MGA, the progesterone derivative CMA has some antiandrogenic activity which corresponds to 20–30% of that of CPA. Owing to the low first-pass metabolism, the bioavailability after oral administration is about 100%. Similar to other progesterone derivatives, CMA accumulates in fat tissue and is stored in the endometrium, myometrium, cervix and tubes. Therefore, the clearance is relatively low, and 7 days after application 74% of the dose is excreted [96]. Within 1–2 h after a single oral administration of a combination of 2 mg CMA and 30 µg EE, the serum concentration of CMA reached a maximum of 1.6 ng/ml. During daily intake the CMA levels increased to a steady-state of 2 ng/ml within 2 weeks [97]. CMA has no binding affinity to SHBG and CBG, and 97–99% of the circulating CMA is bound to albumin. The half-lives are 2.4 h ($t_{1/2\alpha}$) and 38 h ($t_{1/2\beta}$) [97, 98]. The main metabolic steps are the reduction of the 3-keto group with preservation of the Δ^4 -double bond, hydroxylation, and deacetylation. Hydroxylation reactions occur at C2 α , C3 α , C3 β , and C15 β and the resulting metabolites are conjugated to sulfates and glucuronides. The latter are excreted in the kidney. The conjugates excreted in the bile, are hydrolysed in the colon and reabsorbed.

As 3 α -hydroxy-CMA has 70% of the antiandrogenic activity, the enterohepatic circulation may be of clinical relevance.

At doses of 2–4 mg, CMA has been observed to increase body temperature by 0.2–0.5 °C. Using doses of 15–20 mg, CMA can improve hot flushes [98]. It has been shown that treatment of normal men with daily 5 mg CMA caused a significant reduction in arterial CO₂ tension and a stimulation of ventilation [66].

Cyproterone Acetate (CPA)

CPA is the progestin with the highest antiandrogen activity, as shown in animal experiments. This effect is brought about by competitive inhibition of the binding of endogenous androgens to the androgen receptor, and is, therefore, dose-dependent. CPA has some glucocorticoid properties, the clinical importance of which is not clarified (e.g. vessel wall, immune system). After oral administration, the bioavailability of CPA is nearly 100%. A single oral dose of 2 mg CPA led to peak serum levels of CPA of about 11 ng/ml. As it has no binding affinity to SHBG and CBG, 93% of the circulating CPA is bound to albumin. CPA accumulates in fat tissue, and the half-lives are 2–8 h ($t_{1/2\alpha}$) and 60 h ($t_{1/2\beta}$) [17]. The accumulation of CPA in fat tissue during daily administration of higher doses of CPA results in a depot-effect and may prevent withdrawal bleeding after cessation of intake. The major metabolic steps are hydroxylation and deacetylation, while the D4-double bond is preserved. The antiandrogenic activity of 15 β -hydroxy-CPA is similar to that of CPA, but the progestogenic efficacy is only 10% of that of CPA [17].

In addition to a CPA containing oral contraceptives, CPA can be used orally or intramuscularly at higher doses for the treatment of severe acne or hirsutism. Oral treatment of postmenopausal women with 5 mg CPA daily has no effect on the lipid metabolism [92].

Medrogestone (MDG)

In contrast to MPA, CMA, and CPA, MDG is not an esterified derivative of 17 α -hydroxyprogesterone, but has a methyl group at C17 α (Fig. 2). The bioavailability of MDG is 100%, and after oral administration of a dose of 10 mg maximal serum concentrations of 10–

15 ng/ml are reached. Similar to other progesterone derivatives, the circulating MDG is largely bound to albumin (90%) and to a small degree to SHBG (2%) and CBG (3%).

The half-lives of MDG are 4 h ($t_{1/2\alpha}$) and 36 h ($t_{1/2\beta}$). The most important metabolic steps are hydroxylation reactions. As there is no information on the binding affinities of MDG to the various steroid receptors, the hormonal pattern of the compound can hardly be estimated. The lack of effect of a sequential addition of 10 mg MDG on the estrogen-induced rise in TG and HDL-CH suggests that MDG has no androgenic properties [17].

■ Retroprogesterones

The common structure of steroid hormones is the arrangement of the four rings in a plane which is achieved by the attachment of the rings in the trans-orientation. The hormonal activities are largely determined by substituents that are located either above (β -position) or below the plane (α -position, indicated by dotted lines). Retroprogesterones are characterized by a conspicuous change in the configuration of the steroid molecule. Owing to the attachment of the B-ring to the C-ring in the cis-conformation, the plane of the A/B-rings is orientated in a 60° angle below the C/D-rings, and the angular C19 methyl group is in the α -position (Fig. 8) [1].

Dydrogesterone (DYD)

DYD is a stereoisomer of progesterone with an additional double bond between C6 and C7 (Figs. 2, 8), and its hormonal pattern and metabolism differ largely from that of the natural progestogen [1]. It is an orally active progestin that is non-thermogenic, non-sedative and does not inhibit gonadotropin release and ovulation. It has weak antiminerocorticoid effects, negligible androgenic and glucocorticoid activities, and no antiandrogenic properties [99]. Oral treatment with 10–20 mg DYD daily caused a sufficient secretory transformation of a proliferated endometrium. The half-life ($t_{1/2\beta}$) is 5–7 h and 24 h after oral administration, and within 24 h 85% of the dose are excreted. Due to the 9 β ,10 α -retro structure of the molecule, both double bonds cannot be enzymatically reduced. The most important metabolic

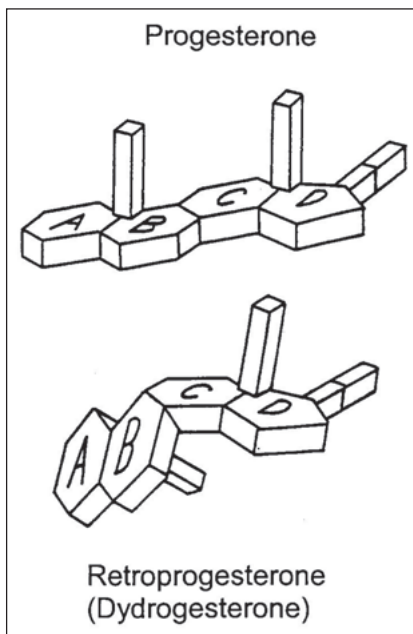

Figure 8. Schematic graph of the configuration of the progesterone and retroprogesterone molecules [1].

steps are the reduction of the 20-keto group, and hydroxylation at C16 α and C21. The main metabolite is 20 α -dihydroprogesterone [1].

The sequential therapy of postmenopausal women with either 1 mg estradiol and 5 or 10 mg DYD or 2 mg estradiol and 10 or 20 mg DYD caused an atrophic or secretory endometrium in most patients and prevented the development of endometrial hyperplasia [100].

■ Norpregnane Derivatives

The 19-norpregnane derivatives are progesterone derivatives that have no angular 19-methyl group (Fig. 2). The hormonal pattern of this group of progestins is similar to that of progesterone derivatives.

Promegestone (PMG)

PMG is a potent progestin and anti-estrogen and is used in HRT at a daily dose of 0.5 mg. It has weak glucocorticoid, but no antimineralocorticoid effects. It does not bind to the androgen receptor and has no androgenic or antiandrogenic activity. PMG is mainly bound to albumin, but not to SHBG and only weakly to CBG. After oral administration, the serum maximum is reached after 1–2 h. The main steps of metabolism are hydroxylation at C21 and other positions of the steroid [32]. The daily administration of 0.5 mg PMG to postmenopausal women did not change the

serum levels of SHBG, angiotensinogen, antithrombin or lipids and lipoproteins [101].

Trimegestone (TMG)

TMG is the most potent norpregnane derivative which causes a secretory transformation of an estrogen-treated endometrium at a daily dose of 0.1 mg. In cyclic HRT, TMG is used at doses of 0.25–0.5 mg daily. After a single oral administration of 1 mg, a maximal serum concentration of TMG of 25 ng/ml is reached within 0.5 h. The half-life was measured as 13.8 h [101]. In the circulation, 98% of TMG is bound to albumin.

TMG has no glucocorticoid or androgenic and a weak antimineralocorticoid and antiandrogenic activity [31, 34]. The main metabolic steps are hydroxylation reactions. The 1 β - and 6 β -hydroxy-TMG-metabolites showed a considerable progestogenic potency with no binding affinity to the other steroid receptors.

Treatment with daily 2 mg estradiol continuously and 0.5 mg TMG on days 15–28 for 13 cycles caused an inactive or secretory endometrium in 85% of the women. The rate of endometrial hyperplasia (without atypia) was 1.9%. The pattern of adverse effects and the cycle control were similar to that of 2 mg estradiol and 0.5 mg norgestrel or 1 mg NETA, except a shorter duration of withdrawal bleeding with TMG [102, 103]. TMG did not counteract the estrogen-induced changes in the lipid metabolism.

Nomegestrol Acetate (NMA)

NMA differs from MGA only by the lack of the angular C19-methyl group. After oral administration of 5 mg NMA, a peak serum level of NMA of 8 ng/ml is reached within 4 h. The bioavailability is about 63%, the half-life ($t_{1/2\beta}$) is 35–50 h, and 98% of NMA is bound to albumin [47, 101, 104, 105]. After a single oral dose of 3.75 mg NMA, a peak level of 7.2 ng/ml is reached after 2–3 h. NMA is inactivated by cytochrome P450 enzymes (CYP3A3, CYP3A4, and CYP2A6) resulting mainly in hydroxylated NMA metabolites.

At a daily dose of 1.25 mg, NMA inhibited ovulation but not follicular growth, whereas 2.5 mg and 5 mg per day suppressed both follicular development and ovulation [106]. In postmenopausal

women treated with estradiol implants, the addition of 0.5 mg, 1 mg, and 2.5 mg NMA for 12 days per cycle caused secretory transformation of the endometrium [107].

NMA shows a pronounced antiandrogenic activity that is between that of CMA and CPA, but no glucocorticoid, antimineralocorticoid or androgenic activity. Treatment of premenopausal women with 5 mg NMA daily did not affect the serum levels of SHBG, CBG, angiotensinogen, HDL-CH, LDL-CH, fibrinogen or plasminogen, but increased antithrombin and reduced triglycerides [108]. The addition of NMA to estrogen therapy did not counteract the estrogen-induced changes in lipid metabolism [101, 108].

Nestorone (NST)

The oral administration of NST is associated with a rapid metabolism and a short half-life of 1–2 h, and the bioavailability is only 10%. After a single oral administration of a solution with 100 μ g NST, the serum level of NST increased rapidly to a maximum of 160 pg/ml within 10 min. Thereafter, it decreased, reaching a value of 80 pg/ml after 1 h.

The binding affinity of NST to the progesterone receptor is similar to that of LNG. NST does not bind to the androgen receptor and has, therefore, no androgenic or antiandrogenic activity. It shows some binding affinity to the glucocorticoid receptor, but exerts no glucocorticoid effects only at high doses. In the circulation, NST is not bound to SHBG, but to albumin and the circulating free fraction is high [109]. After a bolus injection, the half-lives of NST were found to be 3.5 and 83 min [109].

NST is a potent progestin when administered parenterally by means of sustained release formulations.

After subcutaneous application, it was over 100-fold more potent in rats than by the oral route [29].

After 2 years of use of a subdermal implant releasing 100 μ g NST daily, the mean NST serum level was 20 pg/ml [110].

After a single transdermal application of a gel containing 2.3 mg NST to fertile

women, a continuous rise of the NST levels occurred reaching a value of 85 pg/ml after 24 h. During daily application of the gel, the levels increased up to 300 pg/ml on the fifth day of treatment. The results suggest a sustained release of NST from the skin [111].

A metered dose transdermal system using three 90 µl NST sprays per day caused serum NST levels of about 0,1 ng/ml that were sufficient to suppress ovulation [112].

Treatment with vaginal rings releasing 50, 75 or 100 µg NST per day 98% caused an inhibition of ovulation in 98% of the cycles. For lactating women, an implant releasing NST has been developed [109].

■ Nortestosterone Derivatives

The 19-nortestosterone derivatives are derived from the anabolic nandrolone (19-nortestosterone) which has some affinity to the PR (22% of that of progesterone (Fig. 1). The introduction of an ethinyl group at C17 α caused a shift from the androgenic to the progestogenic activity, and the resulting NET is an orally potent progestin with weak androgenic properties (Fig. 1). Further modifications of the steroid skeleton led to various progestins which differ in their potency and pattern of hormonal activities (Tabs. 1, 4). The substitution of the angular methyl group at C13 by an ethyl group led to an increase in the progestogenic potency, as exemplified by the higher potency of LNG as compared to NET (Tab. 4, Fig. 4).

The older progestins norethynodrel, lynestrenol, and ethynodiol diacetate are prodrugs and rapidly transformed after oral administration to the active progestin NET.

Norethisterone (NET) and Norethisterone Acetate (NETA) Oral treatment

After oral administration, NETA is rapidly hydrolyzed to NET in the intestinal tract and liver. Therefore, the pharmacokinetics and pharmacodynamics of NET during treatment with both compounds are similar. The bioavailability of orally administered NET or NETA is 40–80%. The particle size of the administered dose influences the pharmacokinetics of

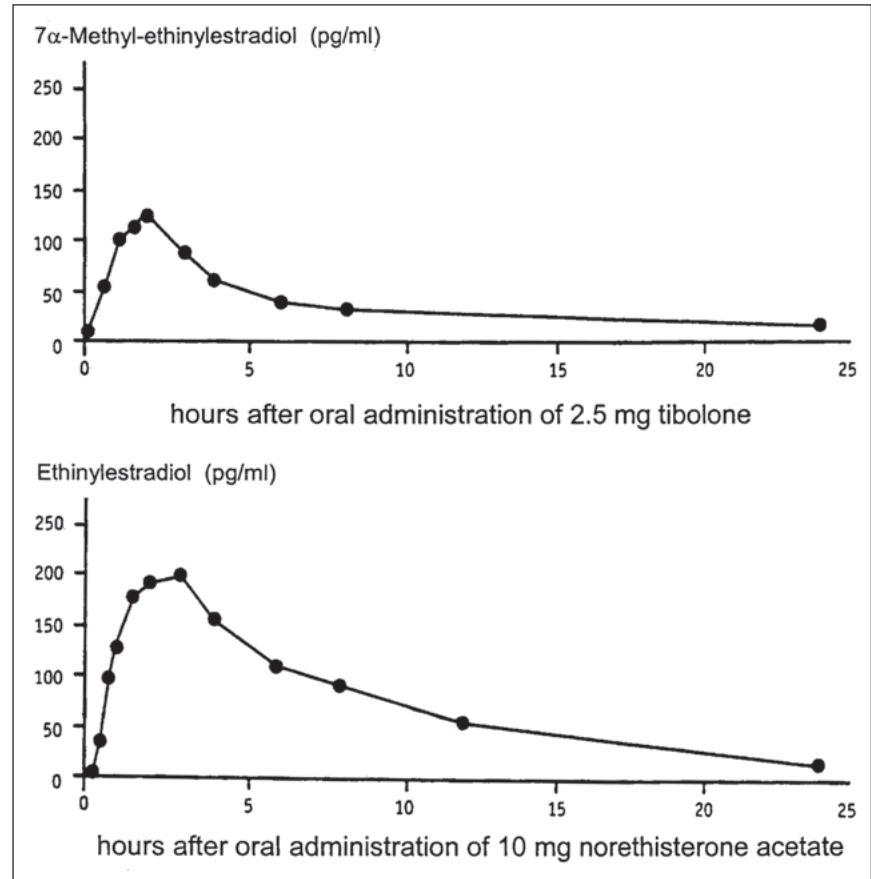

Figure 9. Time course of the serum concentration of 7 α -methyl-ethinylestradiol after oral treatment of fertile women with 2.5 mg tibolone, and time course of the serum concentration of ethinylestradiol after oral treatment of postmenopausal women with 10 mg norethisterone acetate. Mod. from [1, 45, 119].

NET, and smaller particles cause higher serum levels because of faster absorption and lower intestinal metabolism [113]. The concomitant intake of the tablets with a high-fat meal caused lower peak levels but higher AUC of NET as compared with those after administration during fasting [114].

After a single oral administration of 0.5 mg NETA, a maximal serum concentration of NET of about 5 ng/ml on average was reached within 1 h. After intake of 1 mg maximal serum levels of 5–10 ng/ml were measured. When combined with 1 mg estradiol, the pharmacokinetics of NET was found to be similar with a maximum of 5–7 ng/ml [115, 116]. Using a dose of 2 mg NET, a peak NET level of 12 ng/ml was reached. As after 24 h the NET levels had not yet returned to baseline, multiple administration of the estradiol/NET combination resulted in NET levels which were significantly higher by 38% (AUC) with a mean peak level of 7.4 ng/ml after 30 min. A single oral administration of a combination of 1 mg NETA and 2 mg

estradiol resulted in a maximal NET level of 8.5 ng/ml within 1 h [116].

In blood, 36% of NET is bound to SHBG and 61% to albumin. The half-lives are 1.5 h ($t_{1/2\alpha}$) and 9.5 h ($t_{1/2\beta}$) [115]. The main metabolic steps are the reduction of the Δ^4 -double bond to 5 α - or 5 β -dihydro-NET and subsequently the reduction of the 3-keto group to the four isomers of 3,5-tetrahydro-NET. The 5 α -dihydro-NET has a relatively high binding affinity to the androgen receptor and may play a role in the androgenic activity of NET. The ethinyl group is preserved in 90% of all metabolites [117]. Despite the steric hindrance by the 17 α -ethinyl group, conjugation of the 17 β -hydroxy group takes place to a certain extent which may undergo enterohepatic circulation. A small proportion of the NET dose (0.35%) is aromatized to EE, and the concentration-time curve of EE suggests that is formed in the liver [45, 118]. Using a dose of 1 mg, the levels of EE are low and, in the presence of a natural estrogen, probably without clinical relevance [118]. Using doses of 5 mg

or 10 mg, the EE peak levels are similar to those after ingestion of 30 or 60 µg EE (Fig. 9) [45].

NET has no glucocorticoid or anti-mineralocorticoid activity, but a weak androgenic effect.

Transdermal Treatment

Treatment with a patch releasing daily 0.25 mg NETA leads to serum concentrations of 0.5–1 ng/ml which are reached on the second day after application [120]. This is followed by a continuous decrease to a value of 0.25–0.5 ng/ml until the application of a new patch after 3.5 days.

During transdermal treatment with daily 100 µg estradiol and 0.34 mg NETA (two patches with 50 µg estradiol and 0.17 mg NETA) NET serum levels of 0.65 ng/ml were measured.

Continuous transdermal treatment of postmenopausal women for 12 months with 50 µg estradiol combined with 0.14 mg, 0.25 mg or 0.4 mg NETA, endometrial hyperplasia was prevented. The incidence of uterine bleeding (no bleeding in 50% of the cycles) was lowest in the group using estradiol and 0.14 mg NETA. The improvement of hot flushes was similar in all groups. Application-site reactions, mostly erythema, were reported by 25% of the women [121].

Continuous therapy for 1 year with a patch releasing daily 25 µg estradiol and 0.125 mg NETA prevented endometrial hyperplasia and caused a higher rate of amenorrhea (90%) than 50 µg estradiol and 0.25 mg NETA (65%) or an oral therapy with 2 mg estradiol and 1 mg NETA (79%) [122, 123]. Continuous treatment with 25 µg estradiol and 0.125 mg NETA increased significantly bone mineral density in postmenopausal women [124].

The sequential addition of transdermal 0.14 mg, 0.25 mg or 0.40 mg NETA on days 15–28 to the continuous therapy with 50 µg estradiol daily reduced vasomotor symptoms significantly in all three groups [125]. The sequential therapy with patches releasing 50 µg estradiol alone and those combined with NETA 0.25 mg daily resulted in a similar symptom improvement, although a slight re-

duction in efficacy was noted during the combined phase for some symptoms [120].

Transdermal treatment with 50 µg estradiol continuously and in addition 0.17 mg NETA or 0.35 mg NETA either continuously or sequentially (day 15–28) reduced vasomotor symptoms to a similar degree (by >90%) [126]. All regimens caused an effective endometrial protection, and no significant difference in the rate of bleeding was observed between the lower and the higher dose of NETA [113].

The sequential transdermal treatment with 50 µg estradiol and 0.25 mg NETA caused regular bleeding in 80%, irregular bleeding in 11% and no bleeding in 9% of the cycles. The rate of endometrial hyperplasia was 2% [127]. The sequential therapy with patches releasing 50 µg estradiol without and with 0.25 mg NETA caused a slight decrease in total CH, LDL-CH, HDL-CH and apolipoproteins B and A1, and a pronounced reduction in total TG [120]. In contrast to the oral treatment with NETA, transdermal estradiol/NETA does not adversely affect carbohydrate metabolism [120].

Levonorgestrel (LNG) and Norgestrel (NG)

The racemate D,L-norgestrel (NG) consists in equal shares of the potent progestin LNG and the hormonally inactive dextronorgestrel. Therefore, the hormonal activity of 0.5 mg NG is identical to that of 0.25 mg LNG. LNG is a potent progestin exerting some androgenic activity, but no glucocorticoid or anti-mineralocorticoid properties (Tab. 1).

Oral Treatment

After oral administration, the two stereoisomers are metabolised in different ways. The bioavailability of LNG is about 95%. Within 1–2 h after a single oral administration of 150 µg LNG to young women, a maximal serum level of 4.3 ng/ml was measured [128]. Within 1 h after a single ingestion of 50 µg LNG and 30 µg EE, the maximal serum level of LNG was 2.0 ng/ml, with 100 µg LNG and 20 µg EE 2.4 ng/ml, and with 125 µg LNG and 30 µg EE a peak level of LNG of 4.3 ng/ml were measured [129, 130]. The administration of 2 mg estradiol and 0.3 mg LNG to postmenopausal women resulted in a peak serum

level of LNG of 6.2 ng/ml after 1 h which declined thereafter with a terminal half-life of 32 h.

In the blood, 48% of LNG is bound to SHBG and 50% to albumin. The half-lives are 1 h ($t_{1/2\alpha}$) and 24 h ($t_{1/2\beta}$). Owing to its androgenic activity, oral treatment with LNG alone may reduce the SHBG levels, whereas a combination with potent estrogens may cause an increase in SHBG. This may influence the pharmacokinetics of LNG. The main metabolic pathways of LNG are the reduction of the Δ^4 -3-keto group and hydroxylation reactions [49].

Intrauterine treatment

The T-shape LNG-releasing intrauterine device (LNG-IUD) is approved for contraception, but offers some advantages if used for endometrial protection in perimenopausal and postmenopausal women. The vertical Silastic arm contains 52 mg LNG which is released after insertion at a low rate for 5 years. During the first year, it releases 20 µg LNG per day and in the fifth year 15 µg daily. A small proportion of the daily dose appears in the circulation, and during the use of the IUD releasing 20 µg daily, serum LNG levels of about 0.5 ng/ml were measured after 6 and 12 months [131]. A smaller LNG-IUD releasing only 10 µg daily which was developed for postmenopausal women, caused LNG levels of 0.2 ng/ml after 6 and 12 months, respectively [131].

The frameless FibroPlant-LNG IUD is a completely flexible device releasing 14 µg LNG daily. It caused a profound endometrial suppression and amenorrhea in 64% of perimenopausal women and 100% of postmenopausal patients. It is suitable for the reduction of menstrual bleeding in women with menorrhagia [132].

After insertion of the LNG-IUDs, the progestin accumulates in the endometrium and myometrium and causes a profound suppression of the endometrium. Therefore, after transitory spotting and breakthrough bleeding which occur during the first year after insertion in some women, the endometrium becomes atrophic [131]. In postmenopausal women, the insertion of a LNG-IUD was found to cause pain in approximately 50% and may be difficult in one third of the pa-

tients. Therefore, cervical dilatation and/or paracervical blockade may be necessary [133]. Treatment with the LNG-IUD combined with either 50 µg estradiol transdermally or 2 mg estradiol valerate orally caused a profound suppression of the endometrium for 5 years in all patients, and 64% of the patients were totally amenorrheic [133].

The results of various studies with the 20 µg LNG-IUD demonstrate that the endometrial effects and the safety profile in postmenopausal women using estrogens for HRT, are similar to those observed in fertile women. Moreover, the morphological changes in the endometrium are similar to those occurring after oral use of progestins in HRT [134]. In the presence of potent estrogens, the systemic effects, e.g. on metabolic parameters, of the low serum levels of LNG are negligible. There are, however, no data on the effect on breast tissue and breast cancer risk.

In postmenopausal women, the use of a smaller LNG-IUD releasing 10 µg LNG daily was demonstrated to be easier and to cause less pain. During continuous oral treatment with 2 mg estradiol valerate, the use of this LNG-IUD caused a strong endometrial suppression and prevented endometrial hyperplasia. The bleeding pattern was similar to that using the LNG-IUD releasing 20 µg LNG per day [131]. When combined with 2 mg estradiol valerate orally, a significant increase in HDL-CH and decrease in total CH, LDL-CH and lipoprotein (a) was measured 6 months after insertion of the 20 µg LNG-IUD and the 10 µg LNG-IUD. The favourable effect on HDL-CH was maintained after 12 months with the lower dosed IUD, but was reversed with the 20 µg LNG-IUD [131]. The most frequent adverse effects during use of the LNG-IUDs were bleeding, headache, abdominal pain, mastalgia and vaginal discharge.

Transdermal Treatment

Treatment of postmenopausal women with a 7-day sequential matrix patch releasing 50 µg estradiol and 10 µg LNG per day resulted in estradiol levels of 30 pg/ml and LNG levels of 120 pg/ml on average. This therapy improved climacteric symptoms significantly, but did not change the serum levels of lipids and lipoproteins. Moderate to severe appli-

cation-site reactions were observed in less than 10% of the women [135].

After 1 year of sequential treatment of postmenopausal women with 7-day matrix patches releasing daily 50 µg estradiol and 10 µg LNG, 75 µg estradiol and 15 µg LNG or 100 µg estradiol and 20 µg LNG, the rate of endometrial hyperplasia was below 1% [136]. The frequency of cyclic bleeding and of intermittent bleeding was lowest with the 50 µg estradiol/10 µg LNG patch and increased with the hormone dose [137]. Application-site reactions were observed in 5% of the women [136].

Sequential transdermal treatment with daily 80 µg estradiol in the first 2 weeks and 50 µg estradiol plus 20 µg LNG in the following 2 weeks did not alter the SHBG levels, but changed bone markers indicating a reduction of bone resorption and reduced LDL-CH [138].

Continuous combined HRT with 7-day patches releasing daily 45 µg estradiol and 15 µg, 30 µg or 40 µg LNG improved significantly climacteric symptoms and prevented endometrial hyperplasia. After 9 months, amenorrhea was achieved in one third of the patients. Application-site reactions occurred in 30–44%, vaginal hemorrhagia in 29–37% and mastalgia in 16–23% of the women [139].

Norgestimate (NGM)

NGM is a prodrug which after oral administration is rapidly metabolised. Therefore, using an oral dose of 250 µg NGM, only low serum levels of NGM (70 pg/ml) can be measured. It is rapidly transformed by a 2-step metabolism through LNG-3-oxime and LNG-17β-acetate into LNG. The deacetylation of NGM to LNG-3-oxime occurs in the intestinal mucosa and the liver, and the transformation of the LNG-3-oxime to LNG mainly in the liver [49]. As only small amounts of LNG-17β-acetate appear in the circulation, it plays nearly no role in the mechanism of action, despite a high binding affinity to the PR. Consequently, the hormonally active metabolites are LNG and LNG-3-oxime (norelgestromine, deacetylated NGM; Fig. 6) which differ in their binding affinities to the PR (Tab. 2). In contrast to LNG, NGM and its metabolites LNG-3-oxime and LNG-17β-acetate are not bound to SHBG and CBG. Therefore, the amount

of free and albumin-bound LNG-3-oxime was 0.19 nmol/l and 6.5 nmol/l, whereas that of free and albumin-bound LNG was only 0.05 nmol/l and 0.58 nmol/l [140]. The inactivation takes place through reduction and hydroxylation reactions resulting in the formation of LNG-metabolites.

After a single oral administration of 35 µg EE and 250 µg NGM, the level of LNG-3-oxime rose to 2.5 ng/ml after 1.5 h and decreased thereafter rapidly, whereas the LNG maximum of 0.5 ng/ml appeared later and was followed by a slow decline [141]. During daily intake, the level of LNG-3-oxime increased up to 3 ng/ml and the half-life ($t_{1/2\beta}$) was 17 h [48]. After multiple oral administration of 1 mg estradiol continuously and 180 µg NGM intermittently, a peak level of LNG-3-oxime of only 0.64 ng/ml was measured [142].

The regimen used for HRT is 1 mg estradiol continuously and 90 µg NGM intermittently (a 6-day repeating sequence with NGM for 3 days, followed by 3 days without NGM) [142]. It caused a significant improvement in climacteric symptoms and increased bone mineral density. The rate of adverse effects was similar to other continuous combined therapies with 1 mg estradiol and a progestin. The bleeding pattern was not better than that in women treated continuously with a combination of 2 mg estradiol and 1 mg NETA. The data on the risk of endometrial hyperplasia during treatment with the intermittent estradiol/NGM regimen are inconsistent [142].

Dienogest (DNG)

The structure and hormonal pattern of DNG differs from that of other nortestosterone derivatives in so far as it contains at C17α no ethinyl group but a cyanomethyl group (Fig. 4). The lack of an ethinyl group is associated with a lack of an irreversible inhibition of CYP enzymes which is caused by ethinylated steroids through the oxidatively activated ethinyl group [49]. As CYP enzymes are involved both in the ovarian steroid synthesis and the inactivation of steroid hormones, ethinylated progestins – as well as EE – may directly impair follicular activity and inhibit their own degradation. This may explain the relatively low dose of the other nortestosterone derivatives as compared to DNG.

DNG is the only nortestosterone derivative which exerts no androgenic, but an antiandrogenic activity which is about 30% of that of CPA. Despite the relatively low binding affinity to the PR, DNG shows a strong progestogenic effect on the endometrium. The transformation dose of 6.3 mg per cycle is similar to that of LNG. This is probably due to the high serum levels of DNG after administration and, hence, high intracellular concentrations, because the proportion of non-protein-bound DNG in the circulation is 10% due to the lacking binding affinity to SHBG or CBG. DNG has also no estrogenic, glucocorticoid or antiminerocorticoid activity, and does not antagonize the estrogen-induced alterations of certain hepatic serum proteins [49].

Orally administered DNG is rapidly absorbed and the bioavailability is about 95%, but the elimination half-life is relatively short ($t_{1/2\beta}$, 9.1 h). After a single oral administration of 2 mg DNG and 30 µg EE, a peak level of DNG of 53 ng/ml is reached within 2 h. This is followed by a rapid decline to 7 ng/ml after 24 h [49]. The main metabolic steps are the reduction of the Δ^4 -3-keto group, hydroxylation reactions and the elimination of the cyano group.

■ Spirolactone Derivatives

Drospirenone (DRSP)

The chemical structure of DRSP that is a derivative of 17α -spirolactone, is similar to that of the aldosterone antagonist spironolactone (Fig. 4). It has a moderate binding affinity to the PR, a high binding affinity to the mineralocorticoid receptor, but a low binding affinity to the androgen receptor (Tab. 2) [143]. The progestogenic activity of DRSP in the endometrium corresponds to 10% of that of LNG. Therefore, daily doses of 3 mg DRSP are used in HRT preparations. Owing to the strong antiminerocorticoid effect of DRSP, treatment of fertile women with 2 mg alone during the follicular phase caused an increase in sodium excretion, but this was compensated for by a rise in the plasma renin activity by 100% and the aldosterone serum levels by 65% [144]. The antiandrogenic activity of DRSP is about 30% of that of CPA. It has no estrogenic and no appreciable glucocorticoid activity [145].

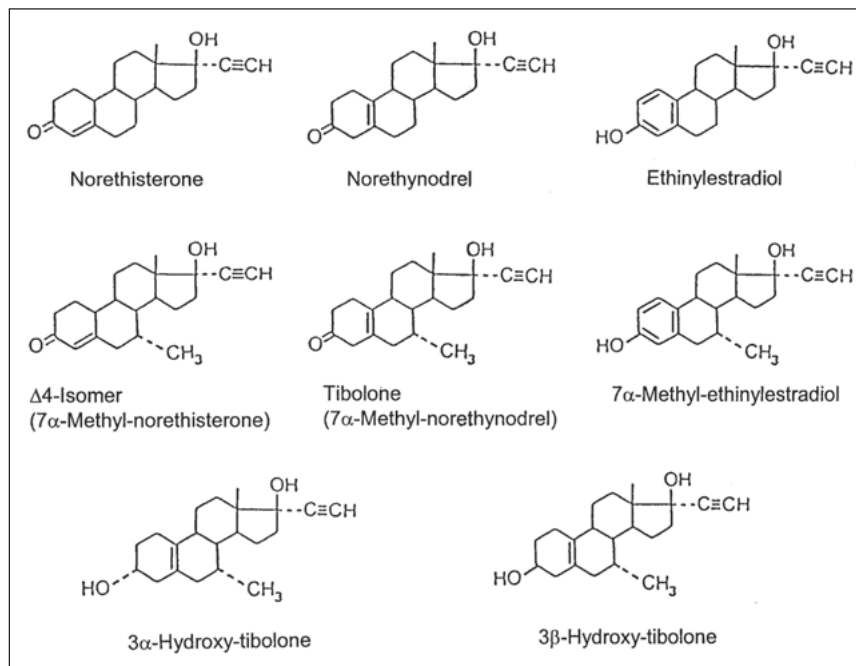

Figure 10. Structural formulae of the prodrugs norethynodrel and tibolone, and their hormonally active metabolites [1].

DRSP has an oral bioavailability between 76% and 85%. It has no binding affinity to SHBG and CBG and the majority of the circulating compounds is bound to albumin; in the blood about 3–5% are non-protein-bound, free DRSP.

After a single administration of 3 mg DRSP a peak serum level of 35 ng/ml is reached within 1–2 h. Thereafter, the levels decline, but after 24 h DRSP concentrations of 20–25 ng/ml can still be measured. Consequently, DRSP accumulates in blood during multiple dosing, and treatment with DRSP in combination with a potent estrogen leads to a peak serum concentration of 60 ng/ml after 7–10 days. The half-lives are 1.6 h ($t_{1/2\alpha}$) and 27 h ($t_{1/2\beta}$). The main metabolic pathways are the opening of the lactone ring leading to an acid group, and the reduction of the Δ^4 -double bond [145].

Continuous combined treatment of postmenopausal women with 1 mg estradiol and 1, 2 or 3 mg DRSP was shown to protect efficiently the endometrium, to improve climacteric complaints and to increase bone mineral density. The use of these formulations caused amenorrhea in 80% of the patients within one year [146]. Owing to the lack of androgenic activity, the estrogen-induced changes in lipid metabolism were not counteracted. The slight blood pressure-lowering effect of estradiol/DRSP com-

binations is similar to that of other HRT preparations containing estradiol and progestins.

■ Tibolone

Pharmacokinetics

Tibolone (TIB) is the 7α -methyl-derivative of norethynodrel (NYD), which was used as a progestin component in the first oral contraceptives. Similar to NYD, TIB is a prodrug and rapidly converted after oral administration in the intestinal tract and the liver to the progestin 7α -methyl-NET (D4-TIB) and some other metabolites (Fig. 10). Following a single administration of 2.5 mg TIB into late postmenopausal women, maximal serum levels of 1.6 ng/ml TIB, 0.8 ng/ml Δ^4 -TIB, 16.7 ng/ml 3α -hydroxy-TIB, and 3.7 ng/ml 3β -hydroxy-TIB were found after 1–2 h [147]. However, a small proportion of TIB is rapidly converted by intestinal and hepatic cytochrome P450 enzymes into the potent estrogen 7α -methyl-ethinylestradiol (MEE). Owing to the lack of the angular C19-methyl group, 19-nortestosterone derivatives are not aromatised by the classical CYP19 aromatase that initially attacks the methyl group between A-ring and B-ring of androgens. The transformation into MEE is in all probability brought about by the oxidation of the A-ring catalyzed by CYP P450 monooxygenases (see below).

TIB has only a weak binding affinity to the steroid receptors, while $\Delta 4$ -TIB is bound to the PR and the androgen receptor with high affinity (Tab. 2). Animal experiments revealed that D4-TIB (7 α -methyl-NET) is a relatively weak progestin, but exerts a strong androgenic effectiveness which is comparable to that of testosterone [33, 148].

Pharmacodynamics

Treatment with TIB led to a suppression of the endometrium which is probably caused by $\Delta 4$ -TIB originating from the circulation and a local conversion of TIB [149]. In a minor part of the women, endometrial proliferation may occur under treatment with TIB [150]. In one third of the patients treated for 3 years with TIB, endometrial polyps have been found [151]. This may be due to the weak progestogenic activity of D4-TIB (7 α -methyl-NET) that is only about 13% of that of NET [33, 148]. This may also explain the significantly elevated risk of endometrial cancer by 100% to 200% during treatment with TIB observed in large cohort studies [57, 152].

During the first months of treatment with TIB, the frequency of irregular bleeding was considerably less than with a combination of 2 mg estradiol and 1 mg NETA, but after 6 months of treatment, there was no difference between both preparations [153].

The strong androgenic activity and the weak progestogenic effectiveness of TIB may account for the reduced proliferation of the breast epithelium and for the reduction in the relative risk of breast cancer by 68% observed in the LIFT study [154]. This might be regarded as contradictory to the increased risk of recurrences in breast cancer patients in the LIBERATE Study [155].

The pronounced androgenic effectiveness of TIB may also explain the increase in some parameters of sexuality, for the less unfavourable changes in haemostatic parameters as compared to estrogen/progestogen combinations, and for the reduction of HDL-CH levels by 30%, triglycerides by 20%, and SHBG by 50% [2, 156–159].

TIB has been demonstrated to relieve hot flushes and atrophic urogenital complaints, and to inhibit bone resorption

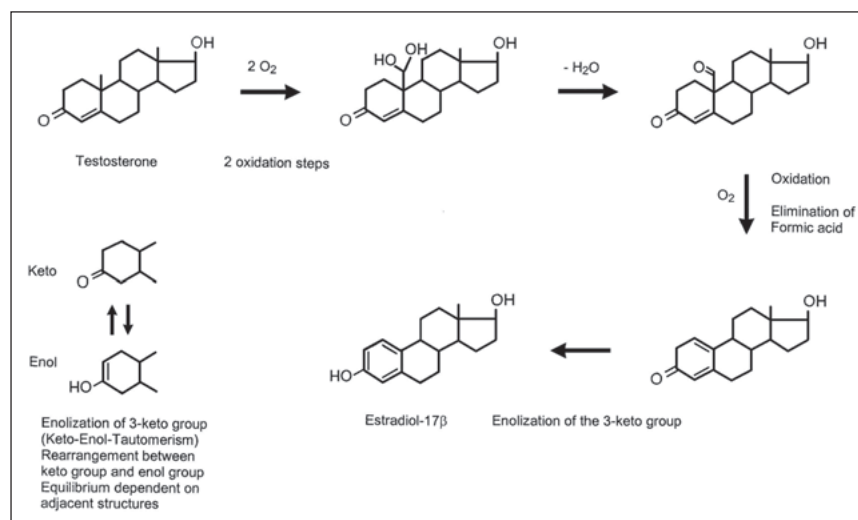

Figure 11. Mechanism of action of the CYP19 aromatase as exemplified by the conversion of testosterone into estradiol-17 β . The formation of a phenolic A-ring is mediated by several oxidation steps catalyzed by the CYP19 aromatase. The key reaction is the oxidative elimination of the angular methyl group located between the A-ring and the B-ring. The final step is an enolization of the keto group at C3, resulting in the phenolic A-ring. Mod. from [162].

[156]. This reflects a strong estrogenic activity of a metabolite of TIB.

The estrogenic effects have been claimed to be caused by the two metabolites 3 α - and 3 β -hydroxy-TIB which show only a weak binding affinity to the ER, but are circulating at high concentrations.

Aromatization of Tibolone and Norethisterone

After oral treatment of ovariectomized rats, TIB was found to be 50 times more estrogenic than NET, and to be more estrogenic than 3 α - and 3 β -hydroxy-TIB which were claimed to be responsible for the pronounced estrogenic activity of TIB (Fig. 10). Moreover, the NET-pro-drug NYD had previously been shown in the Allen-Doisy test to display an estrogenic efficacy 100 times that of NET [13]. As in postmenopausal women NET was demonstrated to be rapidly aromatized to EE after oral administration (Fig. 9) [45, 118], it was probable that the high estrogenic potency of NYD after oral administration is caused by a pronounced conversion to EE. Consequently, it was assumed that TIB is also aromatized after oral administration. This was investigated in a pharmacokinetic trial with young women who were treated during the luteal phase with 2.5 mg TIB. The analysis of the serum samples by means of the gas chromatography/mass spectrometry (GC/MS) method revealed that daily treatment with 2.5 mg TIB leads to a mean peak serum concentration of 7 α -methyl-ethi-

nylestradiol (MEE) of 125 pg/ml after 2 h (Fig. 9) [119]. This suggests that the formation of the highly active estrogen MEE occurs during intestinal resorption and the first liver passage [160].

It has been claimed that the hepatic aromatization of TIB is not possible because the CYP aromatase encoded by the CYP19 gene, is not expressed in the adult human liver. Moreover, using human recombinant CYP aromatase, neither TIB nor NET could be aromatized in vitro. Accordingly, the authors concluded that the formation of EE from NET and of MEE from TIB must be artifacts caused by heating during gas chromatography [161].

The solution of the controversies about the interpretation of the obviously contradictory in vitro and in vivo findings is relatively simple: It is known that aromatisation of a ring system with double bonds is brought about by oxidation and does not need the CYP19 aromatase [162]. However, the latter enzyme is essential to convert testosterone or androstenedione into estradiol or estrone, because the first step of this transformation is the oxidative removal of the angular 19-methyl group (Fig. 11). Contrary to this, in 19-nortestosterone (nandrolone) and 19-nortestosterone derivatives like ethisterone or norethisterone this 19-methyl group and, hence, the substrate for the CYP19 aromatase is lacking [162]. This explains why recombinant CYP aromatase could not aromatise TIB or

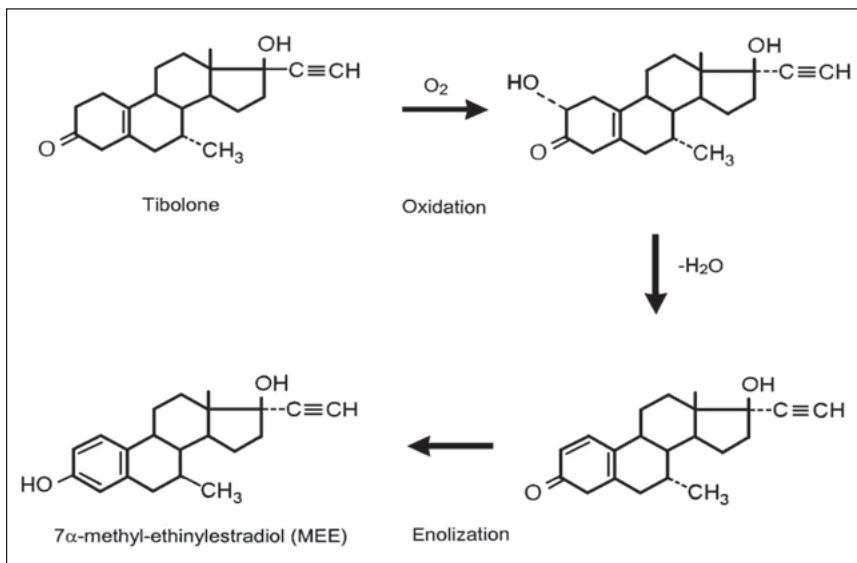

Figure 12. Putative mechanism of aromatization of 19-nortestosterone derivatives as exemplified by the conversion of tibolone into 7 α -methyl-ethinylestradiol. Hydroxylation at C2 α and a further oxidation step lead to the formation of a double bond between C1 and C2. The final step is an enolization of the keto group at C3 resulting in the phenolic A-ring. Mod. from [162].

NET in vitro [161], whereas human liver tissue may convert the 19-nortestosterone derivatives owing to the presence of CYP P450 monooxidases and hydroxylases [162–164]. Oxidation of the A-ring of tibolone or norethisterone results in the introduction of a second double bond and, after enolisation of the 3-keto group, in the formation of a phenolic A-ring (Fig. 12) [74]. This is an easy, rapidly occurring process.

■ Relevancy to Practice

The clinical effects of progestogens are dependent on the dose and route of administration. The various progestogens differ in their pharmacokinetics, hormonal pattern, potency, metabolism, and, consequently, in their tissue-specific effects. Therefore, the knowledge of the pharmacologic properties and peculiarities of progesterone and the synthetic progestins allows the choice of appropriate formulations for an individual treatment.

■ Conflict of Interest

The author declares that there is no conflict of interests.

References:

- Kuhl H. Pharmacology of estrogens and progestogens: influence of different routes of administration. *Climacteric* 2005; 8 (Suppl 1): 3–63.
- Steingold KA, Laufer L, Chetkowski RJ, Defazio JD, Matt DW, Medlrum DR, Judd HL. Treatment of hot flashes with transdermal estradiol administration. *J Clin Endocrinol Metab* 1985; 61: 627–32.

- Jung-Hoffmann C, Kuhl H. Intra- and interindividual variations in contraceptive steroid levels during 12 treatment cycles: no relation to irregular bleedings. *Contraception* 1990; 42: 423–38.
- Lopes P, Rozenberg S, de Graaf J, et al. Aerodiol versus the transdermal route: perspectives for patient preference. *Maturitas* 2001; 38 (Suppl 1): S31–S39.
- Mattsson LA. Safety and tolerability of pulsed estrogen therapy: key factors for an improved compliance. *Climacteric* 2002; 5 (Suppl 2): 40–5.
- Inhoffen HH, Hohlweg W. Neue per os-wirksame weibliche Keimdrüsenhormon-Derivate: 17-Aethinyl-oestradiol und Pregnen-in-on-3-ol-17. *Die Naturwissenschaften* 1938; 26/6: 96.
- Hohlweg W, Inhoffen HH. Pregneninolon, ein neues per os wirksames Corpus luteum-Hormonpräparat. *Klin Wschr* 1939; 18: 77–9.
- Clauberg C, Üstün Z. Menstruation – per os erzeugt. Beweis der Wirksamkeit von Progynon C, einem neuen Follikelhormonderivat, und Proluton C, einem neuen Luteohormonpräparat, bei oraler Verabreichung. *Zbl Gynäkol* 1938; 62: 1745–61.
- Fine E, Levin HM, McConnell EL. Masculinization of female infants associated with norethindrone acetate. *Obstet Gynecol* 1963; 22: 210–3.
- Wilkins L. Masculinization of female fetus due to use of orally given progestins. *JAMA* 1969; 172: 1028–32.
- Allen WM, Ehrenstein M. 10-Nor-progesterone, a physiologically active lower homolog of progesterone. *Science* 1944; 100: 251–52.
- Ehrenstein M. Investigation on steroids – VIII. Lower homologs of hormones of the pregnane series: 10-nor-11-desoxycorticosterone acetate and 10-nor-progesterone. *J Org Chem* 1944; 9: 435–56.
- Djerassi C. Steroid research at Syntex: “the pill” and cortisone. *Steroids* 1992; 57: 631–41.
- Ehrenstein M. Synthesis of steroids of the progesterone series. *Chem Rev* 1948; 42: 457–89.
- Birch AJ. Homocyclic compounds. *Ann Rep Prog Chem Soc Lond* 1950; 47: 177–219.
- Giangrande PH, McDonnell DP. The A and B isoforms of the human progesterone receptor: two functionally different transcription factors encoded by a single gene. *Rec Progr Horm Res* 1999; 54: 291–313.
- Kuhl H. Pharmacology of progestogens. Basic aspects – progesterone derivatives. *Menopause Rev* 2001; 6: 9–16.
- Slayden OD, Brenner RM. Hormonal regulation and localization of estrogen, progestin and androgen receptors in the endometrium of nonhuman primates: effects of progesterone receptor antagonists. *Arch Histol Cytol* 2004; 67: 393–409.
- Mote PA, Ballaine RL, McGowan EM, et al. Heterogeneity of progesterone receptors A and B expression in human endo-

metrial glands and stroma. *Hum Reprod* 2000; 15 (Suppl 3): 48–56.

- Narkar M, Kholkute S, Chitlange S, et al. Expression of steroid hormone receptors, proliferation and apoptotic markers in primate endometrium. *Mol Cell Endocrinol* 2006; 246: 107–13.
- Cline JM, Soderqvist G, von Schoultz E, et al. Effects of hormone replacement therapy on the mammary gland of surgically postmenopausal cynomolgus macaques. *Am J Obstet Gynecol* 1996; 174: 93–100.
- Cheng YH, Imir A, Suzuki T, et al. SP1 and SP3 mediate progesterone-dependent induction of the 17 β -hydroxysteroid dehydrogenase type 2 gene in human endometrium. *Biol Reprod* 2006; 75: 606–14.
- Yang S, Fang Z, Gurates B, et al. Stromal PRs mediate induction of 17 β -hydroxysteroid dehydrogenase type 2 expression in human endometrial epithelium: a paracrine mechanism for inactivation of E2. *Mol Endocrinol* 2001; 15: 2093–105.
- Cheng YH, Imir A, Fencki V, et al. Stromal cells of endometriosis fail to produce paracrine factors that induce epithelial 17 β -hydroxysteroid dehydrogenase type 2 gene and its transcriptional regulator Sp1: a mechanism for defective estradiol metabolism. *Am J Obstet Gynecol* 2007; 196: 391: e1–e7.
- Beier S, Düsterberg B, El Etreby MF, et al. Toxicology of hormonal fertility-regulating agents. In: Benagiano G, Diczfalusy E (eds). *Endocrine mechanisms in fertility regulation*. Raven Press, New York, 1983; 261–346.
- Fotherby K, Caldwell ADS. New progestogens in oral contraception. *Contraception* 1994; 49: 1–32.
- Golbs S, Nicolov R, Zimmermann T. Pharmacology of nortestosterone derivatives. *Menopause Rev* 2001; 6/1: 29–44.
- Herkert O, Kuhl H, Sandow J, et al. Sex steroids used in hormonal treatment increase vascular procoagulant activity by inducing thrombin receptor (PAR-1) expression. Role of glucocorticoid receptor. *Circulation* 2001; 104: 2826–31.
- Kumar N, Koide SS, Tsong YY, et al. Nestorone: a progestin with a unique pharmacological profile. *Steroids* 2000; 65: 629–36.
- Losert W, Casals-Stenzel J, Buse M, et al. Progestogens with antiminerocorticoid activity. *Drug Res* 1985; 35: 459–71.
- Philibert D, Bouchoux F, Degryse M, et al. The pharmacological profile of a novel norepregnane progestin (trimegestone). *Gynecol Endocrinol* 1999; 13: 316–26.
- Rozenbaum H. Pharmacology of progesterone and related compounds: dydrogesterone and norepregnane derivatives. *Menopause Rev* 2001; 6: 17–28.
- Schoonen WGEJ, Deckers GH, de Gooijer ME, et al. Hormonal properties of norethisterone, 7 α -methyl-norethisterone and their derivatives. *J Steroid Biochem Mol Biol* 2000; 74: 213–22.
- Wahab M, Al-Azzawi F. Trimegestone: expanding therapeutic choices for the treatment of the menopause. *Expert Opin Invest Drugs* 2001; 10: 1737–44.
- Kontula K, Paavonen T, Luukkainen T, et al. Binding of progestins to the glucocorticoid receptor. Correlation to their glucocorticoid-like effects on in vitro functions of human mononuclear leukocytes. *Biochem Pharmacol* 1983; 32: 1511–8.
- Ojasoo T. Multivariate preclinical evaluation of progestins. *Menopause* 1995; 2: 97–107.
- Phillips AA. Comparison of the potencies and activities of progestogens used in contraceptives. *Contraception* 1987; 36: 181–92.
- Pollow K, Juchem M, Elger W, et al. Dihydrospirorenone (ZK30595), a novel synthetic progestagen – characterization of binding to different receptor proteins. *Contraception* 1992; 46: 561–74.
- Dickey RP, Stone SC. Progestational potency of oral contraceptives. *Obstet Gynecol* 1976; 47: 106–12.
- Greenblatt RB. A new clinical test for the efficacy of progesterone compounds. *Am J Obstet Gynecol* 1958; 76: 626–8.
- Neumann F, Elger W, Nishino Y, et al. Probleme der Dosisfindung: Sexualhormone. *Drug Res* 1977; 27: 296–318.
- Shapiro SS, Dyer RD, Colas AE. Synthetic progestins: in vitro potency on human endometrium and specific binding to cytosol receptor. *Am J Obstet Gynecol* 1978; 132: 549–54.
- Swyer GIM, Little V. Action and uses of orally active progestational steroids. *Proc Roy Soc Med* 1962; 55: 861–3.
- Swyer GIM. Potency of progestogens in oral contraceptives – further delay of menses data. *Contraception* 1982; 26: 23–27.

45. Kuhn W, Heuner A, Hümpel M, et al. In vivo conversion of norethisterone and norethisterone acetate to ethinyl estradiol in postmenopausal women. *Contraception* 1997; 56: 379–85.
46. Guengerich FP. Mechanism-based inactivation of human liver microsomal cytochrome P-450 IIIA4 by gestodene. *Chem Res Toxicol* 1990; 3: 363–71.
47. Guengerich FP. Inhibition of oral contraceptive steroid-metabolizing enzymes by steroids and drugs. *Am J Obstet Gynecol* 1990; 163: 2159–63.
48. Kim-Björklund T, Landgren BM, Hamberger L. Is the contraceptive effect of 300 µg norethisterone mainly peripheral or central? *Contraception* 1992; 45: 57–66.
49. Kuhl H. Comparative pharmacology of newer progestogens. *Drugs* 1996; 51: 188–215.
50. Kuhl H, Jung-Hoffmann C, Storch A, et al. New aspects on the mechanism of action of contraceptive steroids – recent pharmacokinetic studies of low dose formulations. *Adv Contracept* 1991; 7 (Suppl 3): 149–63.
51. Ortiz de Montellano PR. Suicide substrates for drug metabolizing enzymes: mechanisms and biological consequences. *Progr Drug Metab* 1988; 11: 99–148.
52. Ortiz de Montellano PR, Kunze KL. Self-catalyzed inactivation of hepatic cytochrome P-450 by ethinyl substrates. *J Biol Chem* 1980; 255: 5578–85.
53. Neumann F. The physiological action of progesterone and the pharmacological effects of progestogens – a short review. *Postgrad Med J* 1978; 54 (Suppl): 11–24.
54. Levine H, Watson N. Comparison of the pharmacokinetics of Crinone 8% administered vaginally versus Prometrium administered orally in postmenopausal women. *Fertil Steril* 2000; 73: 516–21.
55. Arafat ES, Hargrove JT, Maxson WS, et al. Sedative and hypnotic effects of oral administration of micronized progesterone may be mediated through its metabolites. *Am J Obstet Gynecol* 1988; 159: 1203–9.
56. Nahoul K, Dehennin L, Jondet M, et al. Profiles of plasma estrogens, progesterone and their metabolites after oral or vaginal administration of estradiol or progesterone. *Maturitas* 1993; 16: 185–202.
57. Allen NE, Tsilidis KK, Key TJ, et al. Menopausal hormone therapy and risk of endometrial carcinoma among postmenopausal women in the European Prospective Investigation Into Cancer and Nutrition. *Am J Epidemiol* 2010; 172: 1394–403.
58. Fournier A, Berrino F, Clavel-Chapelon F. Unequal risks for breast cancer associated with different hormone replacement therapies: results from the E3N cohort study. *Breast Cancer Res Treat* 2008; 107: 103–11.
59. Fournier A, Berrino F, Riboli E, et al. Breast cancer risk in relation to different types of hormone replacement therapy in the E3N-EPIC cohort. *Int J Cancer* 2005; 114: 448–54.
60. Gillet JY, Andre B, Faguer B, et al. Induction of amenorrhea during hormone replacement therapy: optimal micronized progesterone dose. A multicenter study. *Maturitas* 1994; 19: 103–15.
61. Moyer D, de Lignieres B, Driguez P, et al. Prevention of endometrial hyperplasia by progesterone during long-term estradiol replacement: influence of bleeding pattern and secretory changes. *Fertil Steril* 1993; 59: 992–7.
62. Pellissier C, Maroni M, Yaneva H, et al. Chlormadinone acetate versus micronized progesterone in the sequential combined hormone replacement therapy of the menopause. *Maturitas* 2001; 40: 85–94.
63. Lane G, Siddle NC, Ryder TA, et al. Dose dependent effects of oral progesterone on the oestrogenised postmenopausal endometrium. *BMJ* 1983; 287: 1241–5.
64. The Writing Group for the PEPI Trial. Effects of estrogen or estrogen/progestin regimens on heart disease risk factors in postmenopausal women. *JAMA* 1995; 273: 199–208.
65. Rylance PB, Brincaat M, Lafferty K, et al. Natural progesterone and antihypertensive action. *BMJ* 1985; 290: 13–4.
66. Mikami M, Tatsumi K, Kimura H, et al. Respiration effect of synthetic progestin in small doses in normal men. *Chest* 1989; 96: 1073–5.
67. Andreen L, Nyberg S, Turkmen S, et al. Sex steroid induced negative mood may be explained by the paradoxical effect mediated by GABA_A modulators. *Psychoneuroendocrinology* 2009; 34: 1121–33.
68. Freeman EW, Weinstock L, Rickels K, et al. A placebo-controlled study of effects of oral progesterone on performance and mood. *Br J Clin Pharmacol* 1992; 33: 293–8.
69. Bulletti C, de Ziegler D, Flamigni C, et al. Targeted drug delivery in gynaecology: the first uterine pass effect. *Hum Reprod* 1997; 12: 1073–9.
70. Miles RA, Paulson RJ, Lobo RA, et al. Pharmacokinetics and endometrial tissue levels of progesterone after administration by intramuscular and vaginal routes: a comparative study. *Fertil Steril* 1994; 62: 485–90.
71. Kleinstein J, Schlegelmilch R, Mazur D, et al. Pharmacokinetic comparison of progesterone capsules with a progesterone gel after vaginal administration. *Drug Res* 2002; 52: 615–21.
72. de Lignieres B, Dennerstein L, Bäckström T. Influence of route of administration on progesterone metabolism. *Maturitas* 1995; 21: 251–57.
73. Fanchin R, de Ziegler D, Bergeron C, et al. Transvaginal administration of progesterone. *Obstet Gynecol* 1997; 90: 396–401.
74. Noe G, Sitruk-Ware R, Zegers-Hochschild F, et al. Endometrial effect of progesterone delivered by vaginal rings in estrogen-treated postmenopausal women. *Climacteric* 2010; 13: 433–41.
75. Nath A, Sitruk-Ware R. Progesterone vaginal ring for contraceptive use during lactation. *Contraception* 2010; 82: 428–34.
76. Ross D, Cooper AJ, Pryse-Davies J, et al. Randomized, double-blind, dose-ranging study of the endometrial effects of a vaginal progesterone gel in estrogen-treated postmenopausal women. *Am J Obstet Gynecol* 1997; 177: 937–41.
77. Cicinelli E, Ragno G, Cagnazzo I, et al. Nasally-administered progesterone: comparison of ointment and spray formulation. *Maturitas* 1991; 13: 313–7.
78. Ottoson UB, Carlström K, Damber JE, et al. Serum levels of progesterone and some of its metabolites including deoxycorticosterone after oral and parenteral administration. *Br J Obstet Gynaecol* 1984; 91: 1111–9.
79. Wren BG. Progesterone creams: do they work? *Climacteric* 2003; 6: 184–7.
80. Carey BJ, Carey AH, Sanjaykumar P, et al. A study to evaluate serum and urinary hormone levels following short and long term administration of two regimens of progesterone cream in postmenopausal women. *Br J Obstet Gynaecol* 2000; 107: 722–6.
81. Cooper A, Spencer C, Whitehead MI, et al. Systemic absorption of progesterone from Progest cream in postmenopausal women. *Lancet* 1998; 351: 1255–6.
82. Elshafie MAA, Ewies AAA. Transdermal natural progesterone cream for postmenopausal women: inconsistent data and complex pharmacokinetics. *J Obstet Gynaecol* 2007; 27: 655–59.
83. Vashisht A, Wadsworth F, Carey A, et al. A study to look at hormonal absorption of progesterone cream used in conjunction with transdermal estrogen. *Gynecol Endocrinol* 2005; 21: 101–5.
84. Wren BG, Champion SM, Zoa Manga R, et al. Transdermal progesterone and its effect on vasomotor symptoms, blood lipid levels, bone metabolic markers, moods, and quality of life for postmenopausal women. *Menopause* 2003; 10: 13–8.
85. Leonetti HB, Longo S, Anasti JN. Transdermal progesterone cream for vasomotor symptoms and postmenopausal bone loss. *Obstet Gynecol* 1999; 94: 225–8.
86. Leonetti HB, Wilson KJ, Anasti JN. Topical progesterone cream has an antiproliferative effect on estrogen stimulated endometriums. *Fertil Steril* 2003; 79: 221–2.
87. Järvinen A, Kainulainen P, Nissilä M, et al. Pharmacokinetics of estradiol valerate and medroxyprogesterone acetate in different age groups of postmenopausal women. *Maturitas* 2004; 47: 209–17.
88. Hellman L, Yoshida K, Zuffo B, et al. The effect of medroxyprogesterone acetate on the pituitary-adrenal axis. *J Clin Endocrinol Metab* 1976; 42: 912–7.
89. Siminoski K, Goss P, Drucker DJ. The Cushing syndrome induced by medroxyprogesterone acetate. *Ann Intern Med* 1989; 111: 758–60.
90. Grecu EO, Weinschelbaum A, Simmons R. Effective therapy of glucocorticoid-induced osteoporosis with medroxyprogesterone acetate. *Calcif Tissue Int* 1990; 46: 294–9.
91. Bamberger CM, Else T, Bamberger AM, et al. Dissociative glucocorticoid activity of medroxyprogesterone acetate in normal human lymphocytes. *J Clin Endocrinol Metab* 1999; 84: 4055–61.
92. Tikkanen MJ, Kuusi T, Nikkilä EA, et al. Postmenopausal hormone replacement therapy: effects of progestogens on serum lipids and lipoproteins. A review. *Maturitas* 1986; 8: 7–17.
93. Eriik Y, Meldrum DR, Lagasse LD, et al. Effect of megestrol acetate on flushing and bone metabolism in postmenopausal women. *Maturitas* 1981; 3: 167–72.
94. Mann M, Keller E, Murgo A, et al. Glucocorticoidlike activity of megestrol. *Arch Intern Med* 1997; 157: 1651–6.
95. Sporrang T, Hellgren M, Samsioe G, et al. Metabolic effects of continuous estradiol-progestin therapy in postmenopausal women. *Obstet Gynecol* 1989; 73: 754–8.
96. Gallegos AJ, Gonzalez-Diddi M, Merino G, et al. Tissue localization of radioactive chlormadinone acetate and progesterone in the human. *Contraception* 1970; 1: 151–61.
97. Curran MP, Wagstaff AJ. Ethinylestradiol/chlormadinone acetate. *Drugs* 2004; 64: 751–60.
98. Kuhl H. Chemie und Pharmakologie von Chlormadinonacetat. In: Loch EG, Schramm G (eds). Chlormadinonacetat bei Androgenisierungserscheinungen. Schattauer, Stuttgart, 1995; 1–24.
99. Tausk M, de Visser J. Pharmacology of orally active progestational compounds: animal studies. In: Tausk M (ed). Pharmacology of the endocrine system and related drugs: progesterone, progestational drugs and antifertility agents. Vol. 2. Pergamon Press, Oxford, 1972; 35–216.
100. Ferenczy A, Gelfand MM, van de Weijer PHM, et al. Endometrial safety and bleeding patterns during a 2-year study of 1 or 2 mg 17β-estradiol combined with sequential 5–20 mg dydrogesterone. *Climacteric* 2002; 5: 26–35.
101. Sitruk-Ware R, Sundaram K. Pharmacology of new progestogens: the 19-norprogesterone derivatives. In: Sitruk-Ware R, Mishell DR (eds). Progestins and Antiprogestins in Clinical Practice. Marcel Dekker, New York 2000; 153–61.
102. Al-Azzawi F, Wahab M, Thompson J, et al. Acceptability and patterns of endometrial bleeding in estradiol-based HRT regimens: a comparative study of cyclical sequential combinations of trimegestone or norethisterone acetate. *Climacteric* 2001; 4: 343–54.
103. Meuwissen JHJM, Beijers-De Bie L, Vihtamaki T, et al. A 1-year comparison of the efficacy and clinical tolerance in postmenopausal women of two hormone replacement therapies containing estradiol in combination with either norgestrel or trimegestone. *Gynecol Endocrinol* 2001; 15: 349–58.
104. Lello S. Norgestrel acetate. Pharmacology, safety profile and therapeutic efficacy. *Drugs* 2010; 70: 541–59.
105. Mueck AO, Sitruk-Ware R. Norgestrel acetate, a novel progestogen for oral contraception. *Steroids* 2011; in press.
106. Bazin B, Thevenot R, Bursaux C, et al. Effect of norgestrel acetate, a new 19-norprogesterone derivative, on pituitary-ovarian function in women. *Br J Obstet Gynaecol* 1987; 94: 1199–204.
107. Fraser DI, Paadwick ML, Whitehead MI, et al. The effects of the addition of norgestrel acetate to post-menopausal oestrogen therapy. *Maturitas* 1989; 11: 21–4.
108. Paris J, Thevenot R, Bonnet P, et al. The pharmacological profile of TXD66 (17α-acteoxy-6-methyl-19-nor-4,6-pregna-diene-3,20-dione), a new oral progestative. *Drug Res* 1983; 33: 710–15.
109. Sitruk-Ware R, Small M, Kumar N, et al. Nestorone®: clinical applications for contraception and HRT. *Steroids* 2003; 68: 907–13.
110. Noe G, Salvatierra A, Heikinheimo O, et al. Pharmacokinetics and bioavailability of ST1433 administered by different routes. *Contraception* 1993; 48: 548–56.
111. Haukkamaa M, Laurikka-Routti M, Heikinheimo O. Transdermal absorption of the progestin ST-1435: therapeutic serum steroid concentrations and high excretion of the steroid in saliva. *Contraception* 1991; 44: 269–76.
112. Fraser IS, Weisberg E, Kumar N, et al. An initial pharmacokinetic study with metered dose transdermal system® for delivery of the progestogen Nestorone® as a possible future contraceptive. *Contraception* 2007; 76: 432–8.
113. Saperstein S, Edgren RA, Jung D, et al. Pharmacokinetics of norethindrone: effect of particle size. *Contraception* 1989; 40: 731–40.
114. Boyd RA, Zegarac EA, Eldon MA. The effect of food on the bioavailability of norethindrone and ethinyl estradiol from norethindrone acetate/ethinyl estradiol tablets intended for continuous hormone replacement therapy. *J Clin Pharmacol* 2003; 43: 52–8.
115. Stadberg E, Westlund P, Landgren BM, et al. Bioavailability of norethisterone acetate alone and in combination with estradiol administered in single or multiple oral doses to postmenopausal women. *Maturitas* 1999; 33: 59–69.
116. Zdravkovic M, Müller M, Larsen S, et al. Bioequivalence and relative bioavailability of three estradiol and norethisterone acetate-containing hormone replacement therapy tablets. *Int J Clin Pharmacol Ther* 2001; 39: 41–6.
117. Braseltone WE, Lin TJ, Ellegood JO, et al. Accumulation of norethindrone and individual metabolites in human plasma

- during short- and long-term administration of a contraceptive dosage. *Am J Obstet Gynecol* 1979; 133: 154–60
118. Klehr-Bathmann I, Kuhl H. Formation of ethinylestradiol in postmenopausal women during continuous treatment with a combination of estradiol, estriol and norethisterone acetate. *Maturitas* 1995; 21: 245–50.
119. Wiegatz I, Sanger N, Kuhl H. Formation of 7 α -methyl-ethinyl estradiol during treatment with tibolone. *Menopause* 2002; 9: 293–5.
120. Wiseman LR, McTavish D. Transdermal estradiol/norethisterone. A review of its pharmacological properties and clinical use in postmenopausal women. *Drugs Aging* 1994; 4: 238–56.
121. Archer DF, Furst K, Tipping D, et al. A randomised comparison of continuous combined transdermal delivery of estradiol-norethindrone acetate and estradiol alone for menopause. *Obstet Gynecol* 1999; 94: 498–503.
122. Brynhildsen J, Hammar M. Low dose transdermal estradiol/norethisterone acetate treatment over 2 years does not cause endometrial proliferation in postmenopausal women. *Menopause* 2002; 9: 137–44.
123. Mattson LA, Bohnet HG, Gredmark T, et al. Continuous, combined hormone replacement: randomized comparison of transdermal and oral preparations. *Obstet Gynecol* 1999; 94: 61–5.
124. Rubinacci A, Peruzzi E, Bacchi Modena A, et al. Effect of low-dose transdermal E2/NETA on the reduction of postmenopausal bone loss in women. *Menopause* 2003; 10: 241–9.
125. Notelovitz M, Cassel D, Hille D, et al. Efficacy of continuous sequential transdermal estradiol and norethindrone acetate in relieving vasomotor symptoms associated with menopause. *Am J Obstet Gynecol* 2000; 182: 7–12.
126. Rozenberg S, Ylikorkala O, Arrenbrecht S. Comparison of continuous and sequential transdermal progestogen with sequential oral progestogen in postmenopausal women using continuous transdermal estrogen: vasomotor symptoms, bleeding patterns, and serum lipids. *Int J Fertil* 1997; 42 (Suppl 2): 376–87.
127. Lindgren R, Risberg B, Hammar M, et al. Endometrial effects of transdermal estradiol/norethisterone acetate. *Maturitas* 1992; 15: 71–8.
128. Kuhn W, Al-Yacoub G, Fuhrmeister A. Pharmacokinetics of levonorgestrel in 12 women who received a single oral dose of 0.15 mg levonorgestrel and, after a wash-out phase, the same dose during one treatment cycle. *Contraception* 1992; 46: 443–54.
129. Endrikat J, Blode H, Gerlinger C, et al. A pharmacokinetic study with a low-dose oral contraceptive containing 20 μ g ethinylestradiol plus 100 μ g levonorgestrel. *Eur J Contracept Reprod Health Care* 2002; 7: 79–90.
130. Kuhn W, Staks T, Juttig G. Pharmacokinetics of levonorgestrel and ethinylestradiol in 14 women during three months of treatment with a tri-step combination oral contraceptive: serum protein binding of levonorgestrel and influence of treatment on free and total testosterone levels in the serum. *Contraception* 1994; 50: 563–79.
131. Raudaskoski T, Tapanainen J, Tomas E, et al. Intrauterine 10 μ g and 20 μ g levonorgestrel systems in postmenopausal women receiving oral oestrogen replacement therapy: clinical, endometrial and metabolic response. *Br J Obstet Gynaecol* 2002; 109: 136–44.
132. Wildemeersch D, Schacht E, Wildemeersch P. Performance and acceptability of intrauterine release of levonorgestrel with a miniature delivery system for hormonal substitution therapy, contraception and treatment in peri and postmenopausal women. *Maturitas* 2003; 44: 237–45.
133. Varila E, Wahlstrom T, Rauramo I. A 5-year follow-up study on the use of a levonorgestrel intrauterine system in women receiving hormone replacement therapy. *Fertil Steril* 2001; 76: 969–73.
134. Riphagen FE. Intrauterine application of progestins in hormone replacement therapy: a review. *Climacteric* 2000; 3: 199–211.
135. von Holst T, Salbach B. Efficacy of a new 7-day transdermal sequential Estradiol / levonorgestrel patch in women. *Maturitas* 2002; 41: 231–42.
136. Sturdee DW, van de Weijer P, von Holst T, et al. Endometrial safety of a transdermal sequential estradiol-levonorgestrel combination. *Climacteric* 2002; 5: 170–77.
137. van de Weijer PHM, Sturdee DW, von Holst T. Estradiol and levonorgestrel: effects on bleeding pattern when administered in a sequential combined regimen with a new transdermal patch. *Climacteric* 2002; 5: 36–44.
138. Paoletti AM, Piloni M, Orru M, et al. Efficacy and safety of oral and transdermal hormonal replacement treatment containing levonorgestrel. *Maturitas* 2002; 42: 137–47.
139. Shulman LP, Yankov V, Uhl K. Safety and efficacy of a continuous once-a-week 17 β -estradiol/levonorgestrel transdermal system and its effects on vasomotor symptoms and endometrial safety in postmenopausal women: the results of two multicenter, double-blind, randomised, controlled trials. *Menopause* 2002; 3: 195–207.
140. Hammond GL, Abrams LS, Creasy GW, et al. Serum distribution of the major metabolites of norgestimate in relation to its pharmacological properties. *Contraception* 2003; 67: 93–9.
141. Kuhn W, Blode H, Mahler M. Systemic availability of levonorgestrel after single oral administration of a norgestimate-containing combination oral contraceptive to 12 young women. *Contraception* 1994; 49: 255–63.
142. Curran MP, Wagstaff AJ. Estradiol and norgestimate. A review of their combined use as hormone replacement therapy in postmenopausal women. *Drugs Aging* 2001; 18: 863–85.
143. Norman P, Castaner J, Castaner RM. Drospirenone. *Drugs of the Future* 2000; 25: 1247–56.
144. Oelkers W, Berger V, Bolik A, et al. Dihydrospirorenone, a new progestogen with antiminerocorticoid activity: effects on ovulation, electrolyte excretion, and the renin-aldosterone system in normal women. *J Clin Endocrinol Metab* 1991; 73: 837–42.
145. Krattenmacher R. Drospirenone: pharmacology and pharmacokinetics of a unique progestogen. *Contraception* 2000; 62: 29–38.
146. Rubig A. Drospirenone: a new cardiovascular-active progestin with antialdosterone and antiandrogenic properties. *Climacteric* 2003; 6 (Suppl 3): 49–54.
147. Timmer CJ, Verheul HAM, Doorstam DP. Pharmacokinetics of tibolone in early and late postmenopausal women. *Br J Clin Pharmacol* 2002; 54: 101–6.
148. de Gooyer ME, Deckers GH, Schoonen WGEJ, et al. Receptor profiling and endocrine interactions of tibolone. *Steroids* 2003; 68: 21–30.
149. Tang B, Markiewicz L, Kloosterboer HJ, et al. Human endometrial 3 β -hydroxysteroid dehydrogenase can locally reduce intrinsic estrogenic/progestagenic activity ratios of a steroidal drug (Org OD 14). *J Steroid Biochem Molec Biol* 1993; 45: 345–51.
150. Doren M, Rubig A, Coelingh Bennink HJT, et al. Impact on uterine bleeding and endometrial thickness: tibolone compared with continuous combined estradiol and norethisterone acetate replacement therapy. *Menopause* 1999; 6: 299–306.
151. Perez-Medina T, Bajo-Arenas J, Haya J, et al. Tibolone and risk of endometrial polyps: a prospective, comparative study with hormone therapy. *Menopause* 2003; 10: 534–7.
152. Beral V, Bull D, Reeves G. Endometrial cancer and hormone replacement therapy in the Million Women Study. *Lancet* 2005; 365: 1543–51.
153. Hammar M, Christau S, Nathorst-Boös J, et al. A double-blind, randomised trial comparing the effects of tibolone and continuous combined hormone replacement therapy in postmenopausal women with menopausal symptoms. *Br J Obstet Gynaecol* 1998; 105: 904–11.
154. Cummings SR, Ettinger B, Delmas PD, et al. The effects of tibolone in older postmenopausal women. *New Engl J Med* 2008; 359: 697–708.
155. Kenemans P, Bundred NJ, Foidart JM, et al. Safety and efficacy of tibolone in breast-cancer patients with vasomotor symptoms: a double-blind, randomised, non-inferiority trial. *Lancet Oncol* 2009; 10: 135–46.
156. Modelska K, Cummings S. Tibolone for postmenopausal women: systematic review of randomised trials. *J Clin Endocrinol Metab* 2002; 87: 16–23.
157. Nathorst-Boös J, Hammar M. Effect on sexual life – a comparison between tibolone and a continuous estradiol-norethisterone acetate regimen. *Maturitas* 1997; 26: 15–20.
158. Valdivia I, Campodonico I, Tapia A, et al. Effects of tibolone and continuous combined hormone therapy on mammographic breast density and breast histochemical markers in postmenopausal women. *Fertil Steril* 2004; 81: 617–23.
159. Winkler UH, Altkemper R, Kwee B, et al. Effects of tibolone and continuous combined hormone replacement therapy on parameters in the clotting cascade: a multicenter, double-blind, randomized study. *Fertil Steril* 2000; 74: 10–9.
160. Bodine PVN, Harris HA, Lyttle CR, et al. Estrogenic effects of 7 α -methyl-17 α -ethinylestradiol: a newly discovered tibolone metabolite. *Steroids* 2002; 67: 681–6.
161. de Gooyer ME, Oppers-Tiemissen HM, Leysen D, et al. Tibolone is not converted by human aromatase to 7 α -methyl-17 α -ethinylestradiol (7 α -MEE): Analyses with sensitive bioassays for estrogens and androgens with LC-MS/MS. *Steroids* 2003; 68: 235–43.
162. Kuhl H, Wiegatz I. Can 19-nortestosterone derivatives be aromatized in the liver of adult humans? Are there clinical implications? *Climacteric* 2007; 10: 344–53.
163. Urabe M, Yamamoto T, Yoshiji S, et al. Aromatization of norethindrone to ethinylestradiol in human adult liver. *Steroids* 1987; 50: 607–8.
164. Yamamoto T, Yoshiji S, Yasuda J, et al. Aromatization of norethisterone to ethinylestradiol in human adult liver. *Endocrinol Jpn* 1986; 33: 527–31.

Mitteilungen aus der Redaktion

Besuchen Sie unsere Rubrik

[Medizintechnik-Produkte](#)



Neues CRTD Implantat
Intica 7 HF-T QP von Biotronik



Artis pheno
Siemens Healthcare Diagnostics GmbH



Philips Azurion:
Innovative Bildgebungslösung

Aspirator 3
Labotect GmbH



InControl 1050
Labotect GmbH

e-Journal-Abo

Beziehen Sie die elektronischen Ausgaben dieser Zeitschrift hier.

Die Lieferung umfasst 4–5 Ausgaben pro Jahr zzgl. allfälliger Sonderhefte.

Unsere e-Journale stehen als PDF-Datei zur Verfügung und sind auf den meisten der marktüblichen e-Book-Readern, Tablets sowie auf iPad funktionsfähig.

[Bestellung e-Journal-Abo](#)

Haftungsausschluss

Die in unseren Webseiten publizierten Informationen richten sich **ausschließlich an geprüfte und autorisierte medizinische Berufsgruppen** und entbinden nicht von der ärztlichen Sorgfaltspflicht sowie von einer ausführlichen Patientenaufklärung über therapeutische Optionen und deren Wirkungen bzw. Nebenwirkungen. Die entsprechenden Angaben werden von den Autoren mit der größten Sorgfalt recherchiert und zusammengestellt. Die angegebenen Dosierungen sind im Einzelfall anhand der Fachinformationen zu überprüfen. Weder die Autoren, noch die tragenden Gesellschaften noch der Verlag übernehmen irgendwelche Haftungsansprüche.

Bitte beachten Sie auch diese Seiten:

[Impressum](#)

[Disclaimers & Copyright](#)

[Datenschutzerklärung](#)